

# RESTRICTED USE PESTICIDE

DUE TO ACUTE INHALATION TOXICITY OF HIGHLY TOXIC PHOSPHINE (HYDROGEN PHOSPHIDE, PH<sub>3</sub>) GAS

For retail sale to Dealers and Certified Applicators only.

For use by Certified Applicators or persons under their direct supervision, and only for those uses covered by the Certified Applicator's certification. Refer to the directions in this application manual for requirements of the physical presence of a Certified Applicator.

## APPLICATION MANUAL FOR **VAPORPH<sub>3</sub>OS<sup>®</sup> Phosphine Fumigant**

Pure phosphine gas for use after blending with carbon dioxide or forced air in controlling pests in enclosed empty spaces and enclosed space containing stored raw agricultural commodities, processed foods, stored tobacco, animal feeds, and nonfood products. Not for use on barges. This product is the technical grade active ingredient Phosphine and is intended for on-site blending with registered or food grade Carbon Dioxide for the production of a non-flammable fumigant gas. With special equipment, VAPORPH<sub>3</sub>OS<sup>®</sup> may also be blended directly with forced air to a concentration that will be below 55% of the lower flammability limit (LFL) for phosphine. Never use the technical grade phosphine alone for fumigating structures or commodities because of danger of explosion and fire. Refer to the Application Manual for a list of commodities and pests controlled and for Directions for Use.

|                     |               |           |        |
|---------------------|---------------|-----------|--------|
| ACTIVE INGREDIENTS: | Phosphine Gas | By Weight | 99.3%  |
| OTHER INGREDIENTS:  |               |           | 0.7%   |
| TOTAL:              |               |           | 100.0% |



**KEEP OUT OF REACH OF CHILDREN  
DANGER - POISON - PELIGRO**



**PELIGRO AL USUARIO:** Si usted no lee ingles, no use este producto hasta que la etiqueta se le haya sido explicado ampliamente  
**(TO THE USER:** If you cannot read English, do not use this product until the label has been fully explained to you.)

### FIRST AID

Symptoms of exposure to this product are headache, dizziness, nausea, difficult breathing, vomiting and diarrhea. In all cases of overexposure, get medical attention immediately. Take victim to doctor, hospital or emergency treatment facility.

|                   |   |
|-------------------|---|
| <b>If Inhaled</b> | <ul style="list-style-type: none"><li>Move person to fresh air</li><li>If person is not breathing, call 911 or an ambulance, and then give artificial respiration, preferably mouth-to-mouth if possible.</li><li>Call a poison control center or doctor for further treatment advice.</li></ul>  |
| <b>If on Skin</b> | <ul style="list-style-type: none"><li>May cause frostbite to unprotected skin upon contact with dispensing equipment while gas is discharged rapidly.</li><li>Take off contaminated clothing and allow clothes to aerate in ventilated room prior to laundering.</li><li>Call a poison control center or doctor for treatment advice.</li></ul>   |
| <b>If in Eyes</b> | <ul style="list-style-type: none"><li>Hold eye open and rinse slowly and gently with cool water for 15-20 minutes in case of freezing or cryogenic "burns." Do not rinse eyes with hot or even tepid water.</li><li>Remove contact lenses, if present, after the first 5 minutes, then continue rinsing.</li><li>Call a poison control center or doctor for treatment advice.</li><li>Never introduce oil or ointment into eyes without medical advice.</li></ul> |

HAVE THE APPLICATION MANUAL WITH YOU WHEN CALLING A POISON CONTROL CENTER OR DOCTOR OR GOING IN FOR TREATMENT. SEE SIDE PANEL OF LABEL FOR ADDITIONAL PRECAUTIONARY STATEMENTS.

CYTEC Industries Inc., West Paterson, NJ 07424 USA  
Emergency Phone: 1-800/424-9300 or 703/527-3887  
EPA Registration No. 68387-8  
EPA Establishment No. 68387-CAN-1  
Net Contents: 48.5 lbs.

EVERY SHIPMENT OF CYLINDERS IS ACCOMPANIED BY AN APPROVED APPLICATION MANUAL. THIS PRODUCT HAS A REGISTERED LABEL. READ THE ENTIRE LABEL AND THIS APPLICATION MANUAL BEFORE USE. ALL PARTS OF THE LABEL AND APPLICATION MANUAL ARE EQUALLY IMPORTANT FOR SAFE AND EFFECTIVE USE OF THIS PRODUCT. CONSULT WITH YOUR STATE LEAD PESTICIDE REGULATORY AGENCY TO DETERMINE REGULATORY STATUS, REQUIREMENTS, AND RESTRICTIONS FOR FUMIGATION USE IN THAT STATE. CALL CYTEC INDUSTRIES INC. (Tel: 905/374-5828) IF YOU HAVE ANY QUESTIONS OR DO NOT UNDERSTAND ANY PART OF THE PRODUCT LABEL OR APPLICATION MANUAL. IF THE PRODUCT LABEL OR APPLICATION MANUAL IS LOST CONTACT CYTEC INDUSTRIES INC. TO OBTAIN A REPLACEMENT COPY.

REFER TO THE APPLICATION MANUAL FOR DETAILED PRECAUTIONS, RECOMMENDATIONS AND DIRECTIONS FOR USE.

[04/14/2006]

# APPLICATION MANUAL

For

## VAPORPH<sub>3</sub>OS<sup>®</sup> Phosphine Fumigant

### TABLE OF CONTENTS

|  |           |
|--|-----------|
| <b>I. <u>PRECAUTIONARY STATEMENTS</u></b>  | <b>6</b>  |
| <b>A. HAZARDS TO HUMANS AND DOMESTIC ANIMALS</b>   | <b>6</b>  |
| <b>B. NOTE TO PHYSICIAN – THIS IS PHOSPHINE, <u>IT IS NOT PHOSGENE</u></b>                           | <b>6</b>  |
| <b>C. ENVIRONMENTAL HAZARDS</b>  | <b>7</b>  |
| <b>D. PHYSICAL AND CHEMICAL HAZARDS</b>  | <b>7</b>  |
| <b>II. <u>INTRODUCTION</u></b>   | <b>8</b>  |
| <b>A. PRODUCT DESCRIPTION</b>  | <b>8</b>  |
| <b>B. PRODUCT PACKAGING</b>  | <b>8</b>  |
| 1. Packaging   | 8         |
| 2. Blending Equipment for VAPORPH <sub>3</sub> OS <sup>®</sup> Phosphine Fumigant and Carbon Dioxide | 9         |
| 3. Blending Equipment for VAPORPH <sub>3</sub> OS <sup>®</sup> Phosphine Fumigant and Forced Air     | 10        |
| <b>C. PHOSPHINE, AIR AND CARBON DIOXIDE</b>  | <b>11</b> |
| 1. PHOSPHINE   | 11        |
| 2. FORCED AIR  | 12        |
| 3. CARBON DIOXIDE  | 12        |
| <b>III. <u>SAFETY REQUIREMENTS</u></b>   | <b>12</b> |
| <b>A. GENERAL</b>  | <b>12</b> |
| <b>B. SECURING CYLINDERS</b>   | <b>13</b> |
| <b>C. POISON GAS HAZARDS – LEAK DETECTION AND REPAIR</b>   | <b>13</b> |
| 1. Blending Equipment  | 13        |
| 2. Storage Structures  | 14        |
| <b>D. COMPRESSED GAS HAZARDS</b>   | <b>14</b> |
| 1. Gas Discharge   | 14        |
| 2. Temperature   | 14        |
| 3. Residual Pressure   | 14        |
| 4. Liquid Expansion  | 15        |
| <b>IV. <u>DIRECTIONS FOR USE</u></b>   | <b>15</b> |
| <b>A. GENERAL</b>  | <b>15</b> |
| <b>B. PESTS CONTROLLED</b>   | <b>16</b> |
| <b>C. USE PATTERN</b>  | <b>16</b> |
| 1. Pests   | 16        |
| 2. Commodities   | 17        |
| <b>D. DOSAGE GUIDE</b>   | <b>19</b> |
| <b>E. EXPOSURE GUIDELINES</b>  | <b>19</b> |
| <b>F. SEALING</b>  | <b>20</b> |
| <b>G. FUMIGATION MANAGEMENT PLANS</b>  | <b>20</b> |

|              |   |           |
|--------------|---|-----------|
| <b>H.</b>    | <b>APPLICATION PROCEDURES</b>                                 | <b>25</b> |
| 1.           | General Statement   | 25        |
| 2.           | Equipment Specification and Use                               | 25        |
| 3.           | Application to Bulk Commodities                               | 29        |
| 4.           | Application to Space Fumigations                              | 31        |
| 5.           | Application to Tarpaulin Fumigations                          | 32        |
| 6.           | Application to Transport Containers and Trailers              | 34        |
| 7.           | Application To Ships (not for use on barges)                  | 36        |
| <b>V.</b>    | <b><u>PERSONAL PROTECTIVE EQUIPMENT (PPE)</u></b>             | <b>38</b> |
| <b>A.</b>    | <b>GLOVES</b>   | <b>38</b> |
| <b>B.</b>    | <b>SAFETY GLASSES</b>   | <b>38</b> |
| <b>C.</b>    | <b>SAFETY SHOES</b>   | <b>39</b> |
| <b>D.</b>    | <b>HAND TRUCKS</b>  | <b>39</b> |
| <b>E.</b>    | <b>RESPIRATORS</b>  | <b>39</b> |
| <b>F.</b>    | <b>NOTIFICATION REQUIREMENTS</b>                              | <b>40</b> |
| <b>VI.</b>   | <b><u>PLACARDING OF FUMIGATED AREAS</u></b>                   | <b>40</b> |
| <b>VII.</b>  | <b><u>GAS DETECTION EQUIPMENT</u></b>                         | <b>41</b> |
| <b>VIII.</b> | <b><u>AERATION OF FUMIGATED COMMODITIES</u></b>               | <b>41</b> |
| <b>A.</b>    | <b>FOODS AND FEEDS</b>  | <b>41</b> |
| <b>B.</b>    | <b>NON-FOOD COMMODITIES</b>                                   | <b>42</b> |
| <b>C.</b>    | <b>TOBACCO</b>  | <b>42</b> |
| <b>IX.</b>   | <b><u>APPLICATOR AND WORKER EXPOSURE</u></b>                  | <b>42</b> |
| <b>A.</b>    | <b>PHOSPHINE EXPOSURE LIMITS</b>                              | <b>42</b> |
| <b>B.</b>    | <b>CARBON DIOXIDE EXPOSURE LIMITS (IF USED)</b>               | <b>42</b> |
| <b>C.</b>    | <b>APPLICATION OF FUMIGANT</b>                                | <b>42</b> |
| <b>D.</b>    | <b>LEAKAGE FROM FUMIGATED SITES</b>                           | <b>42</b> |
| <b>E.</b>    | <b>AERATION AND REENTRY</b>                                   | <b>43</b> |
| <b>F.</b>    | <b>HANDLING UNAERATED COMMODITIES</b>                         | <b>43</b> |
| <b>G.</b>    | <b>INDUSTRIAL HYGIENE MONITORING</b>                          | <b>43</b> |
| <b>H.</b>    | <b>ENGINEERING CONTROLS AND WORK PRACTICES</b>                | <b>43</b> |
| <b>X.</b>    | <b><u>SAFE HANDLING OF COMPRESSED GASES IN CONTAINERS</u></b> | <b>43</b> |
| <b>XI.</b>   | <b><u>STORAGE OF CYLINDERS</u></b>                            | <b>45</b> |
| <b>A.</b>    | <b>GENERAL</b>  | <b>45</b> |
| <b>B.</b>    | <b>EMERGENCY RESPONSE PLAN</b>                                | <b>45</b> |
| <b>C.</b>    | <b>INDOOR STORAGE</b>   | <b>45</b> |
| <b>D.</b>    | <b>OUTDOOR STORAGE</b>  | <b>45</b> |
| <b>E.</b>    | <b>TEMPERATURE LIMITATIONS</b>                                | <b>46</b> |
| <b>F.</b>    | <b>SECURING CYLINDERS</b>                                     | <b>46</b> |
| <b>G.</b>    | <b>LABELLING OF STORAGE</b>                                   | <b>46</b> |

|                     |   |           |
|---------------------|---|-----------|
| <b><u>XII.</u></b>  | <b><u>TRANSPORT</u></b>                 | <b>46</b> |
| <b>A.</b>           | <b>GENERAL</b>                          | <b>46</b> |
| <b>B.</b>           | <b>TRANSPORT DESIGNATIONS</b>           | <b>47</b> |
| <b>C.</b>           | <b>TRANSPORT REQUIREMENTS</b>           | <b>47</b> |
| 1.                  | Package Preparation                     | 47        |
| 2.                  | Cylinder Contents                       | 47        |
| 3.                  | Documents                               | 47        |
| 4.                  | Vehicle Loading                         | 47        |
| 5.                  | Vehicle Markings                        | 47        |
| 6.                  | Use of Common Carriers                  | 48        |
| 7.                  | Driver Qualifications                   | 48        |
| <b><u>XIII.</u></b> | <b><u>DISPOSAL</u></b>                  | <b>48</b> |
| <b><u>XIV.</u></b>  | <b><u>SPILL AND LEAK PROCEDURES</u></b> | <b>48</b> |
| <b>A.</b>           | <b>GENERAL</b>                          | <b>48</b> |
| <b>B.</b>           | <b>WHAT TO DO</b>                       | <b>48</b> |
| <b>C.</b>           | <b>WHO TO CALL</b>                      | <b>48</b> |
| <b>D.</b>           | <b>EMERGENCY RESPONDERS</b>             | <b>48</b> |

# **I. PRECAUTIONARY STATEMENTS**

## **A. HAZARDS TO HUMANS AND DOMESTIC ANIMALS**

### **Keep Out of Reach of Children DANGER-POISON & PYROPHORIC**

May be fatal if inhaled. Avoid contact with skin and eyes and avoid breathing vapor. Use in well ventilated areas. Keep animals, children and unauthorized persons away from area under treatment until area is shown to be free from Phosphine gas, as indicated by a gas-measuring device. Where the concentration of Phosphine is unknown, a self-contained breathing apparatus (SCBA) with full facepiece and operated in pressure-demand mode must be used.

Do not get in eyes, in nose, on skin or on clothing. Do not eat, drink or smoke while handling VAPORPH<sub>3</sub>OS<sup>®</sup> Phosphine Fumigant. Phosphine gas may deaden the sense of smell. Do not depend solely on the odor to detect VAPORPH<sub>3</sub>OS<sup>®</sup> Phosphine Fumigant. Observe proper application, aeration, and reentry procedures specified in the Application Manual (IX. APPLICATOR AND WORKER EXPOSURE) to prevent overexposure.

**EXPOSURE TO CONCENTRATIONS ABOVE PERMISSIBLE LEVELS MAY CAUSE POISONING.**

## **B. NOTE TO PHYSICIAN – THIS IS PHOSPHINE, IT IS NOT PHOSGENE**

Mild exposure by inhalation causes malaise (indefinite feeling of sickness), ringing of ears, fatigue, nausea and pressure in chest, which are relieved by removal to fresh air. Moderate poisoning causes weakness, vomiting, epigastric pain (pain just above the stomach), chest pain, diarrhea and dyspnea (difficulty in breathing). Symptoms of severe poisoning may occur within a few hours or up to several days, resulting in pulmonary edema (fluid in lungs) and may lead to dizziness, cyanosis (blue or purple skin color), unconsciousness and death.

In sufficient quantity, Phosphine affects the liver, kidneys, lungs, nervous system, and circulatory system. Inhalation can cause lung edema (fluid in lungs) and hyperemia (excess of blood in a body part), small perivascular brain hemorrhages and brain edema (fluid in brain). Phosphine poisoning may result in (1) pulmonary edema, elevated MB-creatine phosphokinase fraction of cardiac enzymes, cardiac dysrhythmia, (2) elevated serum GOT, LDH and alkaline phosphatase, reduced prothrombin, hemorrhage and jaundice (yellow skin color) and (3) hematuria (blood in urine) and anuria (abnormal or lack of urination). Pathology is characteristic of hypoxia (oxygen deficiency in body tissue). Frequent exposure over a period of days or weeks may cause poisoning. Treatment is symptomatic.

The following measures are suggested for use by the physician in accordance with the physician's own judgment:

1. Exposure of skin to rapidly evaporating liquid may cause cryogenic "burn." Treat the "burn" in a similar manner as a thermal burn.
2. In case of freezing or cryogenic "burns" to eyes by rapidly evaporating liquid, RINSE EYES WITH COOL WATER. Do not rinse eyes with hot or even tepid water.
3. In its milder to moderate forms (symptoms of poisoning may take up to 24 hours to make their appearance), the following is suggested:
  - a) Complete rest 1-2 days during which the patient must be kept quiet and warm.
  - b) If the patient suffers from vomiting or increased blood sugar, appropriate solutions should be administered. Treatment with oxygen is recommended, as is the administration of cardiac and circulatory stimulants.

4. In cases of severe poisoning (intensive care unit recommended):
  - a) Where pulmonary edema is observed, steroid therapy should be considered and close medical supervision is recommended. Blood transfusions may be necessary.
  - b) In case of manifest pulmonary edema, venesection should be performed under vein pressure control. Heart glycosides (I.V.) can be used in case of hemoconcentration. Venesection may result in shock. In the case of progressive edema of the lungs, immediately intubate and remove edema fluid and administer oxygen over-pressure respiration, as well as any measures required for shock treatment. In case of kidney failure, extracorporeal hemodialysis is necessary. There is no specific antidote known for this poisoning.

## C. ENVIRONMENTAL HAZARDS

Phosphine is highly toxic to fish and wildlife. Exposure to non-target organisms should be avoided.

## D. PHYSICAL AND CHEMICAL HAZARDS

Phosphine may ignite spontaneously at levels above its Lower Flammability Limit (LFL) of 1.8% v/v (18,000 ppm) in air. It is important not to exceed this concentration. VAPORPH<sub>3</sub>OS<sup>®</sup> Phosphine Fumigant must be blended with Carbon Dioxide or forced air on site using special equipment either specific for Carbon Dioxide or specific for forced air, to produce a non-flammable mixture. When phosphine is blended with Carbon Dioxide, the LFL is raised to 3% v/v (30,000 ppm). When VAPORPH<sub>3</sub>OS<sup>®</sup> Phosphine Fumigant is blended directly with forced air, the concentration of phosphine in the air mixture should be below 10,000 ppm (1% v/v) which is 55% of the LFL.

Ignition of high concentrations of Phosphine can produce a very energetic reaction. Explosions can occur under these conditions and may cause severe personal injury. **Never allow the buildup of Phosphine to exceed flammable concentrations.** Cytec-approved VAPORPH<sub>3</sub>OS<sup>®</sup>/Air blending equipment has been designed to safely blend phosphine in air.

**Contents under pressure. Do not use or store near heat or open flame. Do not puncture or incinerate container. Exposure to temperatures above 130°F may cause bursting. Do not drop the container.**

Never open cylinder in a confined space without an SCBA with full facepiece operated in pressure-demand mode. Never enter a space under fumigation with VAPORPH<sub>3</sub>OS<sup>®</sup> Phosphine Fumigant without first checking the gas concentration levels and wearing the appropriate breathing apparatus. Phosphine gas has a low solubility in water and oils and is stable at normal fumigation temperatures. However, it may react with certain metals and cause corrosion, especially at higher temperatures and relative humidities. Metals such as copper, brass and other copper alloys, and precious metals such as gold and silver are susceptible to corrosion. Thus, small electric motors, smoke detectors, brass sprinkler heads, batteries and battery chargers, fork lifts, temperature monitoring systems, switching gears, communication devices, computers, calculators and other electronic or electrical equipment should be protected or removed before fumigation. In most cases all electronic equipment must be removed. Phosphine gas will also react with certain metallic salts and therefore, sensitive items such as photographic film, some inorganic pigments, etc., should not be exposed. Do not introduce phosphine-CO<sub>2</sub> or phosphine-air mixtures into vacuum chambers.

## WARRANTY

**Seller warrants that the product conforms to its chemical description and when used according to label directions under normal conditions of use, it is reasonably fit for the purpose stated on the label. Seller makes no other warranty, either expressed or implied, and buyer assumes all risk should the product be used contrary to label instructions.**

## II. INTRODUCTION

### A. PRODUCT DESCRIPTION

VAPORPH<sub>3</sub>OS<sup>®</sup> Phosphine Fumigant is a cylinderized source of Phosphine gas and is packaged in high-pressure gas cylinders. VAPORPH<sub>3</sub>OS<sup>®</sup> Phosphine Fumigant cylinders contain 99.3% wt Phosphine as liquefied gas under pressure. Phosphine is pyrophoric and will spontaneously ignite in air. With the use of proper equipment VAPORPH<sub>3</sub>OS<sup>®</sup> can be safely blended with Carbon Dioxide to less than 3% v/v (30,000 ppm of phosphine) or forced air (10,000 ppm of phosphine) to eliminate the flammability hazard.

Phosphine, under sufficient pressure, can exist in a liquid state. It is this “liquefied gas” that is stored in the cylinder. The product is dispensed as a gas from the cylinder and blended with Carbon Dioxide or forced air. When blended with CO<sub>2</sub>, the final blend is similar to ECO<sub>2</sub>FUME<sup>®</sup> Fumigant Gas. ECO<sub>2</sub>FUME<sup>®</sup> Fumigant Gas is the preblended mixture of 2% wt Phosphine in 98% wt Carbon Dioxide. The on-site blending of VAPORPH<sub>3</sub>OS<sup>®</sup> and CO<sub>2</sub> or forced air greatly reduces the number of cylinders that are required. In expanding from a liquid to a gas, it increases in volume by hundreds of times. Proper dispensing equipment is necessary to ensure a safe and effective fumigation.

Unlike metallic phosphide fumigants, Phosphine is not generated through a chemical reaction and its release is instantaneous.

### B. PRODUCT PACKAGING

#### 1. Packaging

VAPORPH<sub>3</sub>OS<sup>®</sup> Phosphine Fumigant is packaged in a steel compressed gas cylinder, designed, manufactured, maintained and filled in compliance with regulations established by the United States Department of Transportation (DOT).

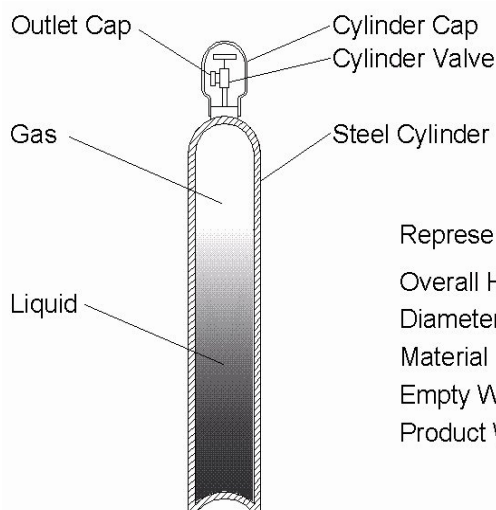

#### Representative Package

|                |                        |
|----------------|------------------------|
| Overall Height | 60 inches (1.52 m)     |
| Diameter       | 9 1/4 inches (23.5 cm) |
| Material       | Steel                  |
| Empty Weight   | 138 pounds (62.6 kg)   |
| Product Weight | 39.7 pounds (18.0 kg)  |

VAPORPH<sub>3</sub>OS<sup>®</sup>  
Phosphine  
Fumigant

The product flows to the blending equipment through the cylinder outlet valve. As gas is withdrawn from the cylinder, some of the product vaporizes to fill the remaining space in the cylinder. Through this vaporization, the cylinder pressure is maintained.

The valve outlet fitting is a CGA350, which was established by the Compressed Gas Association (CGA). The valve outlet is protected by a threaded gas-tight outlet cap, which must be secured whenever the cylinder is not in use. Attach only CYTEC provided (or approved) blending equipment to the cylinder valve outlet to dispense VAPORPH<sub>3</sub>OS<sup>®</sup> Phosphine Fumigant at the time of fumigation. Use of any other blending equipment is prohibited.

Most compressed gas cylinder valves are equipped with a safety device that releases the cylinder contents due to fire exposure or overpressurization. Because VAPORPH<sub>3</sub>OS<sup>®</sup> Phosphine Fumigant is a poisonous gas, Hazard Class A, DOT regulations prohibit the use of such a device.

Each cylinder is supplied with a cylinder cap, which is designed to protect the outlet valve. This cap must be secured whenever a cylinder is not in use. It is unlawful to transport a VAPORPH<sub>3</sub>OS<sup>®</sup> Phosphine Fumigant gas cylinder without the valve outlet cap and the cylinder cap securely in place.

VAPORPH<sub>3</sub>OS<sup>®</sup> Phosphine Fumigant gas cylinders can only be refilled through authorized distributors. They can be filled countless times within a five-year period. Every five years, however, the cylinder is required by law to be tested by a qualified facility.

## **2. Blending Equipment for VAPORPH<sub>3</sub>OS<sup>®</sup> Phosphine Fumigant and Carbon Dioxide**

Phosphine gas (VAPORPH<sub>3</sub>OS<sup>®</sup>) from high pressure cylinders flows into the blender unit where it combines with Carbon Dioxide gas sourced from bulk storage, mobile bulk truck, semi-bulk or cylinders. Various models of on-site blending equipment have been designed, built and tested. All of the designs have incorporated engineering safeguards to ensure that the blended product is a non-flammable mixture.

One design (see diagram below) uses a pressure regulator and flow control orifice on both the VAPORPH<sub>3</sub>OS<sup>®</sup> and CO<sub>2</sub> gases to control the flow rate and properly blend VAPORPH<sub>3</sub>OS<sup>®</sup> with Carbon Dioxide. The size of each orifice is engineered for a specific fixed flow rate and therefore the blending rate cannot be adjusted. By controlling the pressure drop across the orifice plates, the Phosphine concentration can be controlled around 2.5% v/v.

A more sophisticated design uses mass meters, control valves and the electronics to allow an adjustable blending rate while maintaining the proper blend of Phosphine. Engineering controls have been designed into the blending units that will prevent the Phosphine concentration from going outside the range of 2.0 – 2.9% vol (1.6 – 2.2% wt). Mass meters are employed in the design, therefore, the concentration can be precisely controlled to 2.5% v/v (1.9% wt). The product from this equipment is equivalent to ECO<sub>2</sub>FUME<sup>®</sup> fumigant gas.

Blending equipment is intended for use at large facilities that have on-site CO<sub>2</sub> bulk storage and vaporizing equipment, or at facilities where it is feasible to bring in bulk CO<sub>2</sub> and vaporizing equipment for the fumigation. The blending equipment is designed for use only with Carbon Dioxide gas, therefore, a bulk supply of liquid CO<sub>2</sub> must be equipped with suitable vaporizing equipment. Contact Cytec Industries Inc. for blending equipment design specifications and recommendations. For smaller fumigation jobs, it is recommended that pre-blended ECO<sub>2</sub>FUME<sup>®</sup> cylinders be used.

## Diagram of a Representative Type of VAPORPH<sub>3</sub>OS<sup>®</sup> and Carbon Dioxide Blending Equipment

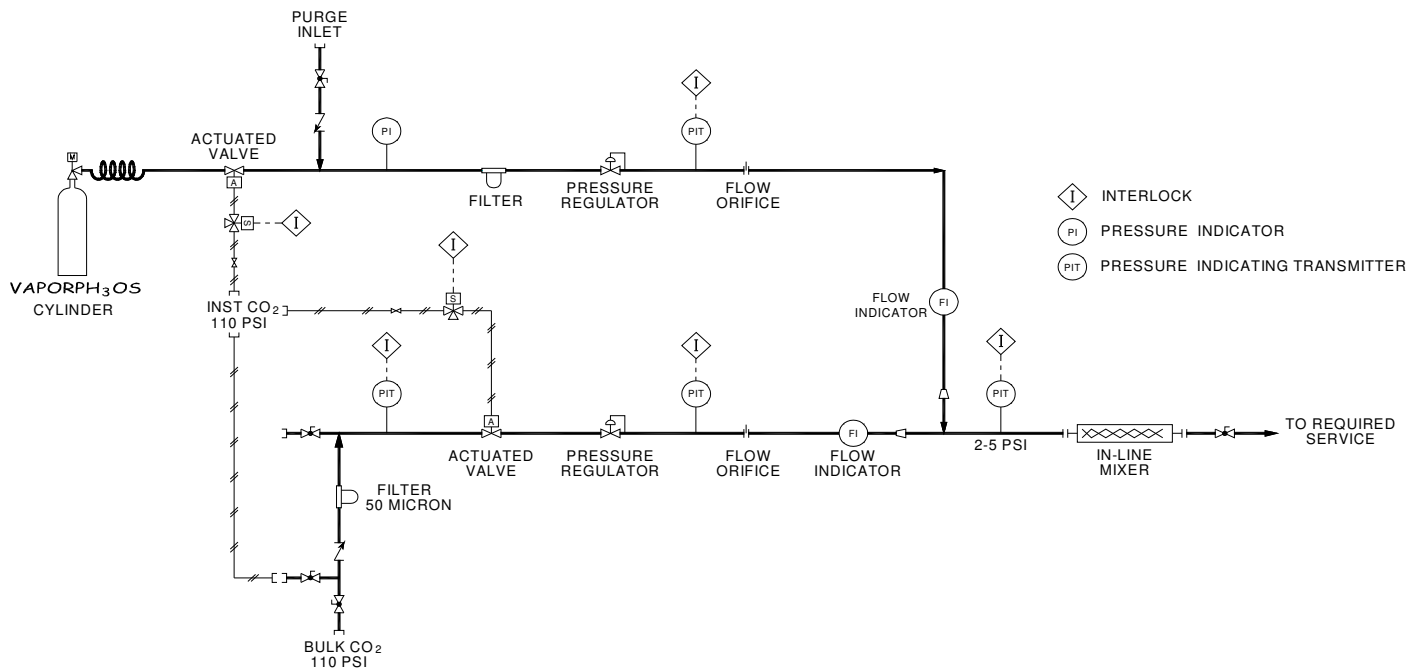

### 3. Blending Equipment for VAPORPH<sub>3</sub>OS<sup>®</sup> Phosphine Fumigant and Forced Air

Phosphine Gas (VAPORPH<sub>3</sub>OS<sup>®</sup>) can ignite spontaneously in air if the concentration is greater than 1.8% (18,000 ppm). With specialized equipment, pure phosphine can be safely blended with a forced air stream to ensure the final concentration does not exceed 10,000 ppm (55% of the Lower Flammability Limit of 18,000 ppm). The equipment has incorporated engineering safeguards to ensure this concentration is never exceeded.

Various models of phosphine/forced air blending equipment have been designed, built, and tested. One design (see diagram below) uses inert gas (Nitrogen or CO<sub>2</sub>) to pre-purge the phosphine lines and equipment. Once purged, phosphine flows through a pressure regulator and flow controller to the mixing point. Here phosphine is safely blended into the forced air stream. The forced air can be supplied by various types of fans, blowers or compressors. The flow of air is measured and the flow of phosphine will stop if the air flow is insufficient. Post purging of the phosphine lines and equipment is also automatic if the phosphine flow is stopped for any reason.

## Diagram of a Representative Type of VAPORPH<sub>3</sub>OS™ and Forced Air Blending Equipment

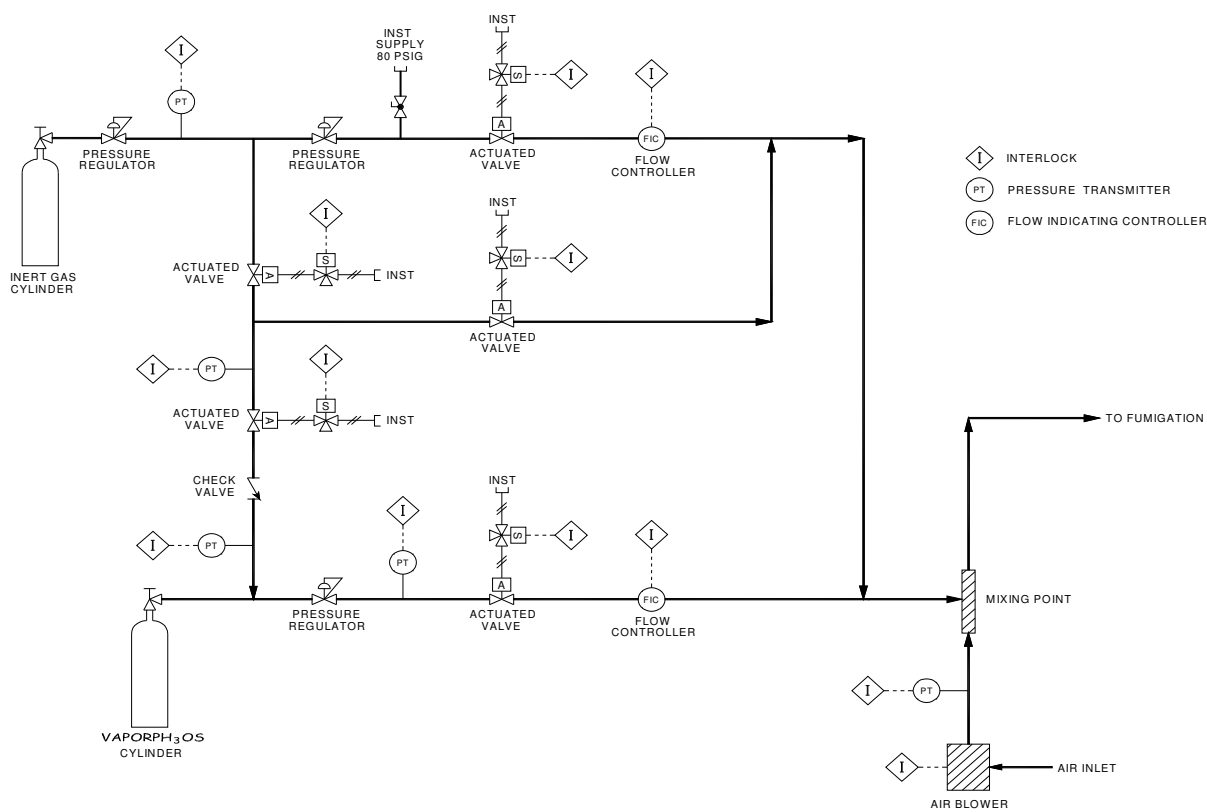

### C. PHOSPHINE, AIR AND CARBON DIOXIDE

#### 1. PHOSPHINE

Phosphine is a colorless gas, which is toxic to insects, humans and other forms of animal life. It is very mobile with a high vapor pressure. Thus, the penetrating capability of Phosphine is great. The combination of high molecular activity, vapor pressure and toxicity to insects at low dosages accounts for its wide acceptance as a fumigant.

Phosphine may ignite spontaneously at levels above its LFL of 1.8% v/v (18,000 ppm) in air. It is important not to exceed this concentration. Ignition of high concentration of Phosphine can produce a very energetic reaction. Explosions can occur under these conditions and may cause severe personal injury.

For worker safety, monitoring for Phosphine is required and suitable breathing apparatus should be used when working in a Phosphine environment. Sometimes Phosphine may have an odor due to the presence of impurities in the product; however, this odor cannot always be relied upon as an adequate indicator of Phosphine exposure.

\*\*VAPORPH<sub>3</sub>OS® Phosphine Fumigant *does not have an expiration date.* Contact Cytex Industries Inc. for any questions \*\*

## 2. FORCED AIR

VAPORPH<sub>3</sub>OS<sup>®</sup> Phosphine Fumigant may be blended with ambient forced air. Cytec supplied (or approved) blending equipment is necessary to ensure Phosphine is safely blended with forced air and will not exceed 55% of the LFL.

## 3. CARBON DIOXIDE

Any registered or food grade source of carbon dioxide may be used with VAPORPH<sub>3</sub>OS<sup>®</sup> Phosphine Fumigant. Carbon dioxide is colorless, non-flammable gas, which at high concentrations or prolonged exposure is toxic. For worker safety, the monitoring for carbon dioxide gas is required and suitable breathing apparatus used. Carbon Dioxide gas is an asphyxiant. Concentrations of 10% or more can produce unconsciousness or death in 1 minute or less.

VAPORPH<sub>3</sub>OS<sup>®</sup> Phosphine Fumigant can be blended only with registered or food grade carbon dioxide products. Follow all label directions for the most restrictive of label limitations and precautions. Consult the carbon dioxide product label for appropriate use, storage and disposal instructions and restrictions.

**Never allow the buildup of Phosphine to exceed explosive concentrations.** When Phosphine is blended with Carbon Dioxide the LFL is raised to 3% v/v.

# III. SAFETY REQUIREMENTS

***VAPORPH<sub>3</sub>OS<sup>®</sup> Phosphine Fumigant is a restricted use product for retail sale and use only by certified applicators and people under their direct supervision.***

## A. GENERAL

1. Carefully read the label and Application Manual and follow instructions explicitly.
2. Never work alone when applying fumigant from within the storage structure (if re-entry is required) or aerating commodities after the fumigation is over.
3. Never allow untrained personnel to handle VAPORPH<sub>3</sub>OS<sup>®</sup> Phosphine Fumigant.
4. The use of respiratory protection may be required as described in Section V. E. of this manual.
5. Post-VAPORPH<sub>3</sub>OS<sup>®</sup> Phosphine Fumigant fumigation placards on fumigated areas, including all entrances/ exits. See Section VI for specific wording that must appear on these placards. Ensure that no personnel are inside any of the structures to be fumigated prior to initiating fumigation.
6. Notify appropriate owners, employees, and/or operators at the facility each time prior to initiating fumigation and provide relevant safety, health, and environmental information to local fire and rescue officials annually for use in the event of an emergency.
7. Worker exposure to Phosphine must not exceed the 8-hour Time-Weighted Average (TWA) of 0.3 ppm during application or a maximum concentration of 0.3 ppm after application is completed. This includes reentry into a structure.
8. Worker exposure to carbon dioxide must not exceed the Threshold Limit Value (TLV) of 5,000 ppm
9. (0.5 % by volume) at any time, either during or after application.

10. Workers required to use SCBA should be assessed for impaired pulmonary function prior to initial use and at least annually thereafter. Any employees found to have impaired pulmonary function should be referred for medical attention.
11. Protect or remove materials containing metals such as copper, silver, gold and their alloys and salts from corrosive exposure to Phosphine.
12. Do not connect cylinders to blending equipment until all fumigation notice placards have been posted and the space to be fumigated is clear and secured.
13. Wear protective clothing as described in Section V. Respiratory protection requirements are also discussed in Section V.
14. The perimeter of the fumigation area, especially downwind, must be monitored to ensure that Phosphine and carbon dioxide concentrations are kept within acceptable levels outside the fumigation area. Large leaks must be repaired to minimize loss of fumigant and reduce risk of exposure to bystanders and/or occupants of nearby buildings.

## **B. SECURING CYLINDERS**

Cylinders must be secured upright at all times to prevent their being inadvertently knocked over. When cylinder is not connected to dispensing equipment, the valve cap and cylinder cap must be securely installed.

## **C. POISON GAS HAZARDS – LEAK DETECTION AND REPAIR**

Because VAPORPH<sub>3</sub>OS<sup>®</sup> is a poisonous gas, care must be taken to avoid direct exposure. Appropriate procedures must be followed to detect and repair leaks in blending equipment and structures. These are discussed below. Also, see section XIV. of this manual, “SPILL AND LEAK PROCEDURES.”

### **1. Blending Equipment**

Although the blending equipment is designed to contain the gas, small leaks can occur. A Phosphine detector must be used from the beginning until the end of each application to check the integrity of the equipment and any leaks must be corrected immediately. Carbon dioxide or Nitrogen should be used to pressurize and leak-check equipment with soap solution prior to use in the field.

**If any leak is encountered while using VAPORPH<sub>3</sub>OS<sup>®</sup> Phosphine Fumigant clear the immediate area of all personnel.**

Only persons who are wearing a self-contained breathing apparatus (SCBA) with full facepiece and operated in pressure-demand mode or its equivalent are permitted in the area to address the leak. Once the leak has been stopped, the area must be thoroughly ventilated and the air tested with a Phosphine detector. Only after the Phosphine level has dropped below the eight-hour TWA of 0.3 ppm or the Short Term Exposure Level (STEL) of 1 ppm for 15 minutes, or the Carbon Dioxide concentration is less than the TWA of 5000 ppm or the STEL of 30,000 ppm, are unprotected personnel permitted to enter.

If a cylinder leak is detected, refer to equipment troubleshooting in Section IV. H. 2. e. (Directions for Use (IV)-Application Procedures (H)-Equipment Specification and Use (2)-Troubleshooting (e)-Leak in cylinder valve outlet) of this manual for guidance on troubleshooting. Further troubleshooting assistance for a particular piece of blending equipment is addressed in the respective equipment manual.

## **2. Storage Structures**

To reduce the potential for leakage, careful attention should be given to inspection of the storage structure and proper sealing prior to fumigation. Refer to the DIRECTIONS FOR USE, sections IV A. (“GENERAL”) and IV F. (“SEALING”) in this manual, for related guidance.

The perimeter of the fumigation area, especially downwind and in adjacent or nearby buildings, must be monitored to ensure that Phosphine and carbon dioxide concentrations are kept within acceptable levels outside the fumigation area. This involves walking around the structure with a personal monitoring device to determine whether excessive amounts of fumigant are escaping.

If a high level of Phosphine is detected outside the fumigation area, the addition of fumigant must be stopped. Large leaks must be repaired to minimize loss of fumigant and reduce risk of exposure to bystanders and/or occupants of nearby buildings. Appropriate personal protective equipment must be worn when sealing leaks. These repairs must be made from the exterior of the structure whenever possible. If it is necessary to seal a leak from the interior of the structure, the applicator must follow all proper procedures for confined space entry (for details, see IV.A.2. and 3. under Directions for Use and IX.E. under Aeration and Reentry) including wearing SCBA with full face piece and operated in pressure-demand mode.

## **D. COMPRESSED GAS HAZARDS**

VAPORPH<sub>3</sub>OS<sup>®</sup> Phosphine Fumigant cylinders and blending equipment can achieve pressures of over 1000 pounds per square inch. Because of this high pressure, care must be taken to avoid unintentional releases of the product.

### **1. Gas Discharge**

The release of high-pressure gas can be forceful and there is potential for personal injury. High-speed discharge from unsecured flexible components such as hoses or tubing can result in a whipping action. The gas released can also propel small objects in the area. Such airborne objects can injure the eyes and bodies of people in the area.

### **2. Temperature**

The rapid discharge of VAPORPH<sub>3</sub>OS<sup>®</sup> Phosphine Fumigant through blending equipment will result in a chilling effect on parts of the equipment and cylinders. This thermodynamic effect can create temperatures low enough to cause frostbite if touched by unprotected skin. While this chilling is typically evidenced by the formation of ice on the equipment and cylinders, the cold hazard may exist without the formation of ice.

### **3. Residual Pressure**

The chilling of cylinders is the result of the liquefied gas boiling to maintain the pressure in the gas space of the cylinder.

When the cylinder is allowed to warm, the pressure in the cylinder may rise accordingly. For this reason, all cylinders must be treated as if they contain high-pressure gas. Cylinder valves should always be closed before disconnecting the blending equipment.

Prior to the dismantling of VAPORPH<sub>3</sub>OS<sup>®</sup> Phosphine Fumigant blending equipment at the conclusion of fumigation, all residual gas in the equipment should be vented to atmospheric pressure. The cylinder valve

should be closed and the remaining product within the supply line discharged through the dispensing equipment. Cylinders should not be disconnected before ensuring that the line is fully vented and purged.

#### **4. Liquid Expansion**

VAPORPH<sub>3</sub>OS<sup>®</sup> Phosphine Fumigant blending equipment is only designed to blend gas. Never invert the cylinder or lay the cylinder down when dispensing the gas. This may result in liquid product flowing into the blending equipment. Always ensure the cylinder is secured in an upright position.

## **IV. DIRECTIONS FOR USE**

### **A. GENERAL**

1. It is a violation of federal law to use this product in a manner inconsistent with its labeling.

VAPORPH<sub>3</sub>OS<sup>®</sup> Phosphine Fumigant is a Restricted Use Pesticide due to the acute inhalation toxicity of Phosphine, PH<sub>3</sub> gas. For retail sale to and use by Certified Applicators only. For use by Certified Applicators or persons under their direct supervision and only for those uses covered by the certified Applicator's certification. Refer to directions in this application manual for requirements of the physical presence of a Certified Applicator. Before using, read and follow the label precautions and directions on the label and in the VAPORPH<sub>3</sub>OS<sup>®</sup> Phosphine Fumigant Application Manual. Additional copies of this manual are available from: CYTEC Canada Inc., Niagara Falls, Ontario, Canada, Customer Service Department, Phone No. (905) 374-5899 or (905) 374-5901; Fax No. (905) 374-5888.

2. Requirements for Certified Applicator to be present and responsible for all workers:

- a. A Certified Applicator must be physically present, responsible for, and maintain visual and/or voice contact with all fumigation workers during the application of the fumigant. Once the application is complete and the structure has been made secure the certified applicator does not need to be physically present at the site.
- b. A Certified Applicator must be physically present, responsible for and maintain visual and/or voice contact with all fumigation workers during the initial opening of the fumigation structure for aeration. Once the aeration process is secured and monitoring has established that aeration can be completed safely the certified applicator does not need to be physically present and trained person(s) can complete the process and remove the placards.
- c. Persons with documented training in the handling of Phosphine products must be responsible for receiving, aerating and removal of placards from vehicles, transport containers and trailers that have been fumigated in-transit.

3. Requirements for Reentry Following Fumigation:

At least two persons trained in confined space entry must be present during reentry into a fumigated or partially aerated site. One of these two persons should also be a Certified Applicator. One of the persons should serve as an observer while the other enters the facility. The second person should not enter the facility and should seek help in the event of an emergency.

4. Preparation and Notification Requirements for Fumigation Sites:

Prior to applying this product, the storage structure must be inspected to determine if it can be made sufficiently gas tight. The storage structure should be sealed so as to maintain a suitable gas concentration over the time period required for control of insects. Personal exposure monitoring should be conducted by use of personal electronic monitors or low level detection tubes, as appropriate. Notify appropriate owners, employees, and/or operators at the facility where the fumigation will occur, and provide relevant safety, health and environmental information to local fire and rescue officials annually for use in the event of an emergency. For additional information consult the manufacturer and training manual about safe and effective use of VAPORPH<sub>3</sub>OS® Phosphine Fumigant.

5. Do not apply VAPORPH<sub>3</sub>OS® Phosphine Fumigant in vacuum chambers.

6. Protect or remove copper, silver, gold and their alloys from corrosive exposure to Phosphine.

## B. PESTS CONTROLLED

Complete control of listed pests may not always be achieved. Factors contributing to less than 100% control include gas leakage, poor gas distribution, unfavorable exposure conditions, etc. Improperly sealed areas may allow escape to on-fumigated areas. In addition, some insects are less susceptible to Phosphine than others. To maximize control, extreme care must be observed in sealing, higher dosages must be used, exposure periods must be lengthened, proper application procedures must be followed, and temperature and humidity must be favorable.

## C. USE PATTERN

### 1. Pests

VAPORPH<sub>3</sub>OS® Phosphine Fumigant will control the following pests:

*a. Insects, including:*

|                    |                          |                          |
|--------------------|--------------------------|--------------------------|
| Almond Moth        | Angoumois Grain Moth     | Bean Weevil              |
| Cadelle            | Carpet Beetle            | Cereal Leaf Beetle       |
| Cigarette Beetle   | Confused Flour Beetle    | Dermeestid Beetle        |
| Dried Fruit Beetle | Dried Fruit Moth         | European Grain Moth      |
| Flat Grain Beetle  | Fruit Flies              | Granary Weevil           |
| Greater Wax Moth   | Hairy Fungus Beetle      | Hessian Fly              |
| Khapra Beetle      | Indian Meal Moth         | Lesser Grain Borer       |
| Maize Weevil       | Mediterranean Flour Moth | Pea Weevil               |
| Pink Bollworm      | Raisin Moth              | Red Flour Beetle         |
| Rice Weevil        | Rusty Grain Beetle       | Saw-toothed Grain Beetle |
| Spider Beetles     | Tobacco Moth             | Warehouse Beetle         |
| Yellow Meal Worm   | Bees                     |                          |

*b. Rodents and other vertebrate pests.*

*c. Wood pests (specifically the pine wood nematode and other wood-infesting nematodes and beetles)*

## 2. Commodities

The following food commodities can be fumigated with VAPORPH<sub>3</sub>OS® Phosphine Fumigant:

### a. Raw Agricultural Commodities

|                             |  |                 |
|-----------------------------|--|-----------------|
| Almonds                     | Alfalfa                                | Avocado         |
| Banana (includes Plantains) | Barley                                 | Brazil Nuts     |
| Cabbage, Chinese            | Cashews                                | Citrus Citron   |
| Cocoa Beans                 | Coffee Beans                           | Corn            |
| Cottonseed                  | Dates                                  | Dill            |
| Eggplant                    | Endive                                 | Filberts        |
| Flower Seed                 | Grapefruit                             | Grass Seed      |
| Kumquat                     | Legume Vegetables (succulent or dried) |                 |
| Lemon                       | Lettuce                                | Lime            |
| Mango                       | Millet                                 | Oats            |
| Okra                        | Orange                                 | Papaya          |
| Peanuts                     | Pecans                                 | Pepper          |
| Persimmon                   | Pimento                                | Pistachio Nuts  |
| Popcorn                     | Rice                                   | Rye             |
| Safflower Seed              | Salsify Tops                           | Sesame Seeds    |
| Sorghum                     | Soybeans                               | Sunflower Seeds |
| Sweet Potato                | Tangelo                                | Tangerine       |
| Tomato                      | Triticale                              | Vegetable seeds |
| Walnuts                     | Wheat                                  |                 |

### b. Processed Foods

Processed foods that may be fumigated with VAPORPH<sub>3</sub>OS® Phosphine Fumigant:

- Processed candy and sugar
- Cereal flours and bakery mixes
- Cereal foods (including cookies, crackers, macaroni, noodles, pasta, pretzels, snack foods and spaghetti)
- Processed cereals (including milled fractions and packaged cereals)
- Cheese and cheese by-products
- Chocolate and chocolate products (such as assorted chocolate, chocolate liquor, cocoa, cocoa powder, dark chocolate coating and milk chocolate)
- Processed coffee
- Corn grits
- Cured, dried and processed meat products and dried fish
- Dates
- Dried eggs and egg yolk solids
- Dried milk, dried powdered milk, nondairy creamers, and nonfat dried milk
- Dried or dehydrated fruits (such as citrus, apples, dates, figs, peaches, pears, prunes, raisins and sultanas)
- Dried and dehydrated vegetables (such as beans, carrots, lentils, peas, potato flour, potato products and spinach)
- Figs
- Malt
- Peanuts

- Processed herbs, spices, seasonings and condiments
- Processed nuts (almonds, apricot kernels, Brazil nuts, cashews, filberts, peanuts, pecans, pistachio nuts, walnuts and other processed nuts)
- Processed oats (including oatmeal)
- Rice (brewers rice grits, enriched and polished, wild rice)
- Soybean flour and milled fractions
- Processed tea
- Yeast (including primary yeast)
- Wild rice
- Other processed foods

***c. Animal Feed and Feed Ingredients***

All animal feed and feed ingredients.

***d. Nonfood Commodities Including Tobacco***

Nonfood items that may be fumigated with VAPORPH<sub>3</sub>OS® Phosphine Fumigant:

- Animal hide
- Processed or unprocessed cotton, wool and other natural fibers or cloth, including clothing
- Clothing, feathers, furs, human hair, rubberized hair, vulcanized hair, mohair
- Leather products
- Tobacco
- Wood, cut trees, wood chips and wood and bamboo products
- Tires (for mosquito control)
- Paper and paper products
- Non-food flour
- Dunnage
- Non-food starch
- Fresh or dried plants and flowers
- Bulbs, tubers, corms and rhizomes
- Seeds (grass seed, ornamental herbaceous plant seed, and vegetable seed)
- Straw or hay
- Psyllium seed and psyllium seed husks\*\*
- Other nonfood commodities

\*\*Psyllium seed and Psyllium seed husks destined for shipment to pharmaceutical manufacturers may be fumigated. Such dedicated lots may be fumigated in transport vehicles (truck trailers, railcars and containers) prior to shipment. In addition, psyllium seed and husks may be fumigated at other locations only under direct instructions from the pharmaceutical company.

## D. DOSAGE GUIDE

### RECOMMENDED PHOSPHINE DOSAGES FOR VAPORPH<sub>3</sub>OS<sup>®</sup> PHOSPHINE FUMIGANT<sup>1,2</sup>

| Temperature            | PH <sub>3</sub> Concentration Maintained per 1,000 ft <sup>3</sup> of Area | Minimum Duration    |
|------------------------|--|---------------------|
| Below 32°F (0° C)      | Do not fumigate  | Do not fumigate     |
| 32-39° F (0-4° C)      | 200-1,000 ppm  | 6 days              |
| 40-53° F (5-12° C)     | 200-1,000 ppm  | 4 days <sup>3</sup> |
| 54-59° F (12-15° C)    | 200-1,000 ppm  | 3 days              |
| 60-79° F (16-25° C)    | 200-1,000 ppm  | 2 days              |
| 80° F & Above (≥26° C) | 200-1,000 ppm  | 36 hours            |
| 80° F & Above (≥26° C) | 500-1,000 ppm  | 24 hours            |

<sup>1</sup> For other calculations, refer to Section IV.H.2.d.

<sup>2</sup> When fumigating wood or wood products, the fumigation rate may need to be adjusted depending upon the moisture content of the wood or wood product. For best results, fumigate with a dose of 750-1000 ppm phosphine for 10 days. Higher concentrations are recommended to counter the solubility of phosphine in water or moisture present in the wood or wood product. If fumigating for quarantine purposes, check with the receiving country concerning accepted fumigation methods for the specific product being fumigated.

<sup>3</sup> VAPORPH<sub>3</sub>OS<sup>®</sup> Phosphine Fumigant can be used on cocoa beans to control all stages of those moth species (including Indian Meal Moth) that commonly infest cocoa beans in a 24- hour exposure time with 500-1000 ppm phosphine at a temperature of 40°F or higher.

Rodents and other vertebrate pests in storages may be controlled with short-term fumigations within 1 to 4 hours after achieving distribution of phosphine throughout the structure.

**Restriction: After introduction and stabilization, the maximum concentration of phosphine maintained during fumigation should not exceed 1,000 ppm.**

## E. EXPOSURE GUIDELINES

The above table may be used as a guide in determining the minimum length of the exposure at the indicated temperatures. These are the temperatures found within the immediate surroundings of the target pest (cold walls, center of grain mass, etc.). For example, 200 – 500 parts per million of Phosphine from VAPORPH<sub>3</sub>OS<sup>®</sup> Phosphine Fumigant is necessary for a minimum of 2 days at 60-79° F at the location of the pest insect. This does not mean the ambient temperature the fumigator is experiencing but the localized concentration and temperature next to the pest insects.

Some insect species and life stages are harder to kill than others. It is important that target pest(s) are known and understood. For example, overwintering dormant larva may be more difficult to kill than an active larva of the same species. Use of the maximum duration and concentration of Phosphine is recommended when possible. Insects, in general, are more difficult to control at lower temperatures because of factors such as slower respiration and slower diffusion of the fumigant into the space and commodity.

Short treatment times are effective at high temperatures (80°F and above). At these higher temperatures a treatment time of one day is sufficient to kill most storage pests, however, two days may be needed to destroy

100% of the eggs of some storage pests (e.g., *Amyelois transitella*, *tribolium* spp., and *Trogoderma variabile*). Knowing the pest and life stage to control is critical to determining the dose and treatment needed.

Certain stored product insects are more tolerant and harder to kill. Here is a partial list of those insect species: Rice weevil, Granary weevil, Maize weevil (*Sitophilus* spp.), Lesser grain borer (*Rhyzopertha dominica*), Warehouse beetle (*Trogoderma* spp.), Carpet beetle (*Attagenus/Anthrenus* spp.), Cigarette beetle (*Lasioderma serricornis*). Consequently, exposure periods recommended in the table are minimum periods and may not be adequate to control all stages of stored product pests under all conditions. This is particularly true at lower temperatures (below 60 degrees F) due to the lower activity and respiration levels of insects.

Fumigators also should be aware that different types of packaging will influence the penetration rate of the gas. Selection of appropriate exposure should be considered accordingly.

The key to a successful fumigation remains with correct dosage, adequate exposure periods, proper application procedures and well-sealed enclosures.

## **F. SEALING**

Good sealing is necessary for an effective fumigation. Turn off all ventilation, supply air, air conditioning, and any other air moving systems which could negatively effect the fumigation. Thoroughly inspect the fumigation chamber/area and seal all cracks, holes and openings. These areas could include, but are not limited to: windows, doors, vents, chimneys and structural flaws. Sealing techniques can vary, but most often include polyethylene sheeting, adhesive tapes and adhesive sprays. Expandable foam or caulking material can work well on structural flaws. Proper sealing will insure sufficient gas levels within the fumigated area and will decrease the chance of unwanted exposure outside of the fumigated area.

As with all fumigations, perimeter monitoring for leaks and potential exposures is required. If phosphine above 0.3 ppm is found in an area where exposure to workers or bystanders may occur, the addition of fumigant must be stopped. Using the proper protective equipment, the applicator must attempt to seal the leak from the exterior of the structure. Failing this, the applicator must follow all proper procedures for confined space entry including wearing SCBA with full facepiece and operated in pressure-demand mode, and seal the leak from the interior. At times the applicator may find that all the calculated amount of fumigant has been added, however the target concentration has not been reached. In this case, the fumigator must first check the calculations. It is possible the Phosphine concentration is localized and has not had enough time to disperse evenly. Continue to monitor the inside concentration while checking for leaks as above. All structures will leak to some degree. Large leaks must be repaired to minimize loss of fumigant to the environment and reduce risk of potential exposure to personnel. Outside fence-line concentrations must never be allowed to exceed the TLV of 0.3 ppm.

Phosphine gas is highly mobile and given enough time may penetrate seemingly gas-tight materials such as concrete and cinder block. Therefore, adjacent, enclosed areas likely to be occupied must be examined to ensure that significant leakage has not occurred. Sealing of the fumigated site and/or airflow in the occupied areas must be sufficient to bring down the phosphine concentration to a safe level of 0.3 ppm or below.

## **G. FUMIGATION MANAGEMENT PLANS**

The certified applicator is responsible for working with the owners and/or responsible employees of the site to be fumigated to develop a Fumigation Management Plan (FMP). The FMP is intended to ensure a safe and effective fumigation. The FMP must address characterization of the site, and include appropriate monitoring and notification requirements, consistent with, but not limited to, the following:

1. Inspect the structure and/or area to determine its suitability for fumigation.

2. When sealing is required, consult previous records for any changes to the structure, seal leaks, and monitor any occupied adjacent buildings to ensure safety.
3. Prior to each fumigation, review any existing FMP, MSDS, Applicators Manual and other relevant safety procedures with company officials and appropriate employees.
4. Consult company officials in the development of procedures and appropriate safety measures for nearby workers that will be in and around the area during application and aeration.
5. Consult with company officials to develop an appropriate monitoring plan that will confirm that nearby workers and bystanders are not exposed to levels above the allowed limits during application, fumigation and aeration. This plan must also demonstrate that nearby residents will not be exposed to concentrations above the allowable limits.
6. Consult with company officials to develop procedures for local authorities to notify nearby residents in the event of an emergency.
7. Confirm the placement of placards to secure entrance into any area under fumigation.
8. Confirm the required safety equipment is in place and the necessary manpower is available to complete a safe effective fumigation.
9. Written notification must be provided to the receiver of a vehicle that is fumigated in transit.

These factors must be considered in putting a FMP together. It is important to note that some plans will be more comprehensive than others. All plans should reflect the experience and expertise of the applicator and circumstances at and around the structure and/or area.

In addition to the plan, the applicator must read the entire label and application manual and follow their directions carefully. If the applicator has any questions about the development of a FMP contact Cytec Industries Inc. for further assistance.

The FMP and related documentation, including monitoring records, must be maintained for a minimum of 2 years.

## **GUIDANCE FOR PREPARATION OF A FUMIGATION MANAGEMENT PLAN**

### **Purpose**

A Fumigation Management Plan (FMP) is an organized, written description of the required steps involved to help ensure a safe, legal, and effective fumigation. It will also assist you and others in complying with pesticide product label requirements. The guidance that follows is designed to help assist you in addressing all the necessary factors involved in preparing for and fumigating a structure and/or area.

This guidance is intended to help you organize any fumigation that you might perform **PRIOR TO ACTUAL TREATMENT**. It is meant to be somewhat prescriptive, yet flexible enough to allow the experience and expertise of the fumigator to make changes based on circumstances that may exist in the field. By following a step-by-step procedure, yet allowing for flexibility, safe and effective fumigation can be performed.

Before any fumigation begins, carefully read and review the label and the Applicator's Manual. This information must also be given to the appropriate company officials (supervisors, foreman, safety officer, etc.) in charge of the

structure and/or area. Preparation is the key to any successful fumigation. If the type of fumigation that you are to perform is not listed in this Guidance Document you will want to construct a similar set of procedures. Finally, before any fumigation begins you must be familiar with and comply with all applicable state and local laws. The success or the fumigation is not only dependent on your ability to do your job but also upon carefully following all rules, regulations, and procedures required by governmental agencies.

## **A CHECKLIST GUIDE FOR A FUMIGATION MANAGEMENT PLAN**

This checklist is provided to help you take into account factors that must be addressed prior to performing all fumigation's. It emphasizes safety steps to protect people and property. The checklist is general in nature and cannot be expected to apply to all types of fumigation situations. It is to be used as a guide to prepare the required plan. Each item must be considered, however, it is understood that each fumigation is different and not all items will be necessary for each fumigation structure and/or area.

### **A. PRELIMINARY PLANNING AND PREPARATION**

1. Determine the purpose of the fumigation.
  - a. Elimination of pest infestation
  - b. Plant pest quarantine.
2. Determine the type of fumigation, for example
  - a. Space; tarp, mill, warehouse, food plant
  - b. Vehicle; railcar, truck, van, container
  - c. Commodity; raw agricultural or processed foods
  - d. Grain; vertical silo, farm storage, flat storage
  - e. Vessels or ships (not for use on barges). In addition to the Applicator's Manual, read the US Coast Guard Regulations 46CFR 147A.
3. Fully acquaint yourself with the structure and/or area and commodity to be fumigated, including.
  - a. The general structure layout, construction (materials, design, age, maintenance), of the structure fire or combustibility hazards, connecting structures and escape routes, above and below ground, and other unique hazards or structure characteristics. Prepare, with the owner/operator/person in charge. Draw or have a drawing or sketch of structure to be fumigated, delineating features, hazards, and other structural issues.
  - b. The number and identification of persons who routinely enter the area to be fumigated (i.e., Employees, visitors, customers, etc.)
  - c. The specific commodity to be fumigated, its mode of storage, and its condition.
  - d. The previous treatment history of the commodity, if available.
  - e. Accessibility of utility service connections.
  - f. Nearest telephone or other means of communication, and mark the location of these items on the drawing/sketch.
  - g. Emergency shut-off stations for electricity water and gas. Mark the location of these items on the drawing/sketch.
  - h. Current emergency telephone numbers of local Health, Fire, Police, Hospital and Physician responders.
  - i. Name and phone number (both day and night) of appropriate company officials.
  - j. Check, mark and prepare the points of fumigation application
  - k. Review labeling and Applicator's Manual
  - l. Exposure time considerations.

1. Fumigant to be used.
  2. Minimum fumigation period, as defined and described by the label use directions.
  3. Down time required to be available
  4. Aeration requirements
  5. Measured and recorded commodity temperature.
- m. Determination of dosage
1. Cubic footage or other appropriate space/location calculations.
  2. Structure sealing capability and methods.
  3. Label recommendations
  4. Temperature and wind
  5. Commodity/space volume
  6. Past history of fumigation of structure
  7. Exposure time.

## **B. PERSONNEL**

1. Confirm in writing that all personnel in and around the area to be fumigated have been notified prior to application of the fumigant. Consider using a checklist that each employee initials indicating they have been notified.
2. Instruct all fumigation personnel about the hazards that may be encountered; and about the selection of personal protection devices, including detection equipment.
3. Confirm that all personnel are aware of and know how to proceed in case of an emergency situation.
4. Instruct all personnel on how to report any accident and/or incidents related to fumigant exposure. Provide a telephone number for emergency response reporting.
5. Instruct all personnel to report to proper authorities any theft of fumigant and/or equipment related to fumigation.
6. Establish a meeting area for all personnel in case of emergency.

## **C. MONITORING**

1. Perimeter Safety
  - a. Monitoring of phosphine concentrations must be conducted in areas to prevent excessive exposure and to determine where exposure may occur. Document where monitoring will occur.
  - b. Keep a log or manual of monitoring records for each fumigation site. This log must at a minimum contain the timing, number of readings taken and level of concentrations found in each location.
  - c. When monitoring, document there is no phosphine present above the safe levels, subsequent monitoring is not routinely required. However spot checks must be made, especially if conditions significantly change.
  - d. Monitoring must be conducted during aeration and corrective action taken if gas levels exceed the allowed levels in an area where bystanders and/or nearby residents may be exposed.
2. Efficacy
  - a. Gas readings should be taken from within the fumigated structure to ensure proper gas concentrations. This can be safely achieved from outside the structure through the use of sample lines.
  - b. All phosphine readings should be documented.

## **D. NOTIFICATION**

1. Confirm that all appropriate local authorities (fire departments, police departments, etc.) have been notified as per label instructions, local ordinances if applicable, or instructions of the client.

2. Prepare written procedure (“Emergency Response Plan”) which contains explicit instructions, names, and telephone numbers so as to be able to notify local authorities if phosphine levels are exceeded in an area that could be dangerous to bystanders and/or domestic animals.
3. Confirm that the receivers of vehicles and containers under in-transit fumigation have been notified and that trained workers will be available on site (IV. H. 6. c. under DIRECTIONS FOR USE).

#### **E. SEALING PROCEDURES**

1. Sealing must be adequate to control pests. Care should be taken to ensure that sealing materials will remain intact until the fumigation is complete.
2. If the structure and/or area has been fumigated before, review the previous FMP for previous sealing information.
3. Make sure that construction/remodeling has not changed the building in a manner that will affect the fumigation.
4. Warning placards must be placed on every possible entrance to the fumigation site.

#### **F. APPLICATION PROCEDURES & FUMIGATION PERIOD**

1. Plan carefully and apply all fumigants in accordance with the label requirements.
2. When entering into the area under fumigation always work with two or more people under the direct supervision of a certified applicator wearing appropriate respirators.
3. Apply fumigant from the outside the fumigation space.
4. Provide watchmen when a fumigation site cannot otherwise be made secure from entry by unauthorized persons.
5. When entering structures always follow OSHA rules for confined spaces.
6. Document that the receiver of vehicles fumigated in transit has been notified and is trained to receive commodity under fumigation.

#### **G. POST-APPLICATION OPERATIONS**

1. Provide watchmen when you cannot secure the fumigation site from entry by unauthorized persons during the aeration process.
2. Ventilate and aerate in accordance with structural limitations.
3. Turn on ventilating or aerating fans where appropriate.
4. Use a suitable gas detector before reentry to determine fumigant concentration.
5. Keep written records of monitoring to document completion of aeration.
6. Consider temperature when aerating.
7. Ensure aeration is complete before moving vehicle into public roads.
8. Remove warning placards when aeration is complete.
9. Inform business/client that employees/other persons may return to work or otherwise be allowed to reenter the aerated structure.

## H. APPLICATION PROCEDURES

### 1. General Statement

A Fumigation Management Plan (FMP) (see Section IV. G above.) must be prepared for all structures and containers before fumigation is started in order to prevent human and animal exposure to phosphine and to help assure adequate control of insect pests.

The following instructions are intended to provide general guidelines for typical fumigation. There are a number of critical factors involved in the design of blending equipment. As such, blending equipment must meet both high-pressure standards and chemical compatibility requirements. Improper or inappropriate use of blending equipment may result in severe injury or death. Application inconsistent with the labeling and Application Manual is a violation of Federal law. Buyer assumes all risk should the product be used contrary to label or Application Manual instructions.

### 2. Equipment Specification and Use

#### *a. General*

The equipment used to blend VAPORPH<sub>3</sub>OS<sup>®</sup> Phosphine Fumigant on site with CO<sub>2</sub> or Forced Air provides a means of containing the gas during the application and controlling the release of the product into the desired space. The development of suitable blending equipment is an ongoing process, based on the needs of the users and available technology. Only equipment designed or approved by Cytec Industries Inc. may be used.

The design of blending equipment must account for a number of technical issues, including pressure rating, material compatibility, temperature limitations, operator safety, and controlling the Phosphine concentration between 2.0 – 2.9% v/v when blended with CO<sub>2</sub> or less than 10,000 ppm (55% of the LFL) when blended with Forced Air. For this reason, only appropriate equipment should be used in the blending of VAPORPH<sub>3</sub>OS<sup>®</sup> Phosphine Fumigant. Only persons trained in the proper use of VAPORPH<sub>3</sub>OS<sup>®</sup> Phosphine Fumigant and the blending equipment (specific to blending with Forced Air or CO<sub>2</sub>) shall be permitted to use VAPORPH<sub>3</sub>OS<sup>®</sup> Phosphine Fumigant for fumigation.

The instruction materials provided with the blending equipment should be consulted for its proper use and maintenance.

#### *b. Unapproved Dispensing Methods*

It has been common practice, with other cylinderized fumigants, to place the cylinder in the space to be fumigated and the cylinder outlet valve opened to allow the fumigant to release. This is not an approved dispensing method and must never be used with VAPORPH<sub>3</sub>OS<sup>®</sup> Phosphine Fumigant. VAPORPH<sub>3</sub>OS<sup>®</sup> Phosphine Fumigant is pyrophoric and will spontaneously ignite in air. The cylinder containing VAPORPH<sub>3</sub>OS<sup>®</sup> Phosphine Fumigant must be placed outside the fumigation area and properly blended with Carbon Dioxide or using specialized equipment with Forced Air, to eliminate the flammability hazard.

#### *c. Approved Blending Methods*

VAPORPH<sub>3</sub>OS<sup>®</sup> Phosphine Fumigant and approved blending equipment is generally used for large fumigations that would otherwise require the use of multiple ECO<sub>2</sub>FUME<sup>®</sup> pre-blended cylinders. Some facilities may have bulk Carbon Dioxide storage tanks on site.

The approved CO<sub>2</sub> blending equipment has incorporated required safety features to properly blend Phosphine and Carbon Dioxide into a non-flammable mixture with a Phosphine concentration between 2.0 – 2.9% vol.

The approved Forced Air blending equipment has incorporated required safety features to properly blend Phosphine and Forced Air to ensure the concentration of Phosphine does not exceed 55% of the LFL (10,000 ppm).

***d. Calculating the Amount of VAPORPH<sub>3</sub>OS® Phosphine Fumigant Required***

The amount of VAPORPH<sub>3</sub>OS® Phosphine Fumigant and CO<sub>2</sub> required to perform a fumigation will depend on (i) type of space to be fumigated and its sealability, (ii) type of commodity, (iii) type of insect pest, its life stage and resistance level, (iv) temperature of the infestation site, (v) duration of fumigation, (vi) use of any re-circulation devices and (vii) whether or not it is a stationary or ins-transit fumigation. An initial dose of VAPORPH<sub>3</sub>OS® Phosphine Fumigant and CO<sub>2</sub>/Forced Air is used to establish a pesticidal atmosphere in the fumigation space, and through active monitoring of the Phosphine concentrations, additional VAPORPH<sub>3</sub>OS® Phosphine Fumigant and CO<sub>2</sub>/Forced Air added as required to maintain the target concentration for the prescribed time period.

The initial dose of fumigant is based on the total volume of the space to be fumigated and the target Phosphine concentration desired. When blending VAPORPH<sub>3</sub>OS® Phosphine Fumigant with CO<sub>2</sub> and forced air, it is sometimes easier to speak in terms of the amount of Phosphine that is required rather than the amount of blended gas required. The maximum concentration of VAPORPH<sub>3</sub>OS® Phosphine Fumigant used per fumigation should not exceed 1,000 ppm of Phosphine.

**One gram of Phosphine (PH<sub>3</sub>) will produce a concentration of 25 parts per million (ppm) in a volume of 1000 cubic feet (ft<sup>3</sup>). This is the fundamental conversion used when calculating the amount of VAPORPH<sub>3</sub>OS® Phosphine Fumigant needed to dose a space.**

|   |
|---|
| $1 \text{ gram PH}_3 = 25 \text{ ppm PH}_3/1000 \text{ ft}^3$ $1 \text{ pound of VAPORPH}_3\text{OS}^\circ \text{ Phosphine Fumigant} = 454 \text{ grams PH}_3$ |
|---|

To calculate the total amount of Phosphine or VAPORPH<sub>3</sub>OS® Phosphine Fumigant required to dose a space:

|   |
|---|
| $\text{grams of PH}_3 = (\text{Target Conc.} \times \text{Volume}) / 25,000$ <p>“Target” is the desired Phosphine concentration in parts per million (ppm)<br/>“Volume” is the empty volume of the space to be fumigated in cubic feet (ft<sup>3</sup>)</p> |
|---|

To calculate the amount of Phosphine or VAPORPH<sub>3</sub>OS® Phosphine Fumigant to be added to a space to reestablish the Target concentration:

|   |
|---|
| $\text{grams of PH}_3 = (\text{Target Conc.} - \text{Actual}) \times \text{Volume} / 25,000$ <p>“Actual” is the measured Phosphine concentration in parts per million (ppm)<br/>“Target” is the desired Phosphine concentration in parts per million (ppm)<br/>“Volume” is the empty volume of the space to be fumigated in cubic feet (ft<sup>3</sup>)</p> |
|---|

## 1. Blending with CO<sub>2</sub>

Manuals for approved blending equipment are available from authorized VAPORPH<sub>3</sub>OS® Phosphine Fumigant distributors.

As a general rule, 200 ppm of PH<sub>3</sub> from VAPORPH<sub>3</sub>OS® Phosphine Fumigant when blended with Carbon Dioxide will produce 8,000 ppm of carbon dioxide in the fumigation space.

Once the amount of Phosphine has been determined, the appropriate amount of Carbon Dioxide required can be calculated. The lower explosion limit for a blend of Phosphine in CO<sub>2</sub> is 3% vol Phosphine or 2.3% wt. The blending equipment is designed to produce a blend of 2.5% vol (1.9% wt) Phosphine in Carbon Dioxide. Engineering controls have been designed into the blending equipment that will prevent the Phosphine concentration from going outside the range of 2.0 – 2.9% vol (1.6 – 2.2% wt). It is recommended, as shown in the formula below, that twice this amount of Carbon Dioxide be available to ensure that an adequate supply is available for initial dose, redosing, and equipment purging.

$$\text{lb CO}_2 \text{ required} = \frac{\text{gms PH}_3 \text{ required}}{454 \text{ gms/lb}} \times \frac{2}{0.019}$$

## 2. Blending with Forced Air

Manuals for approved blending equipment are available from authorized VAPORPH<sub>3</sub>OS® Phosphine Fumigant distributors.

When blending with forced air only the amount of phosphine needs to be calculated. It is sometimes desirable to source the air supply from inside the fumigation space thereby establishing a closed circulation system. In this way a positive pressure will not develop within the fumigation space. If recirculation is not used the displacement of air from the fumigation space will occur and perimeter monitoring for phosphine should be performed. The blending equipment provided with VAPORPH<sub>3</sub>OS® Phosphine Fumigant dispenses approximately 20 grams of phosphine per minute and an air flow of 50 standard cubic feet per minute (SCFM). The air blending equipment is controlled by programmable sequence controllers that automatically shut down the dispensing of phosphine if the minimum air flow is not maintained.

## 3. General

When adding VAPORPH<sub>3</sub>OS® Phosphine Fumigant to a space, the Phosphine concentration should be actively monitored. This can be accomplished from outside the space by use of plastic sample tubing run through an opening and securely attached to a point inside the space. If the desired concentration is achieved before the calculated amount of VAPORPH<sub>3</sub>OS® Phosphine Fumigant has been added, close the phosphine cylinder to stop the blending of VAPORPH<sub>3</sub>OS® Phosphine Fumigant with CO<sub>2</sub> or forced air and the calculations should be checked. It is possible that a localized higher concentration has been detected and the gas requires more time to evenly disperse.

The Phosphine in a full cylinder of VAPORPH<sub>3</sub>OS® Phosphine Fumigant weighs 39.7 lbs (18 kg). When a partial cylinder is required, the cylinder can be placed on a scale and the amount of fumigant released can be weighed. The scale should have a maximum capacity for at least 200 lb (90.7 kg) to accommodate the cylinder weight. It should also have an accuracy of ± 10% of the

phosphine dosage. Example: if 2.2 lb (1000 gm) of phosphine is required, the scale should have an accuracy of  $\pm 0.22$  lb (100 gm). This should ensure that the target phosphine concentration can be maintained within 10% of the desired value. The scale can also be used to check how much VAPORPH<sub>3</sub>OS® Phosphine Fumigant is left in the cylinder by comparing this weight to the tare weight. The tare weight is stamped near the top of the cylinder and distinguished with the letters "TW". Subtract the tare weight from the measured weight and the difference is the amount of product left in the cylinder.

Quantifying the amount of the CO<sub>2</sub> or forced air used based on cylinder weight is unnecessary because the blending equipment automatically dispenses the proper amount as the Phosphine is introduced.

### *e. Troubleshooting*

This section is provided to assist in addressing problems that may be encountered while using VAPORPH<sub>3</sub>OS® Phosphine Fumigant cylinders. In the event of a potential leak in the structure, refer to Section IV. F. SEALING. When troubleshooting leaking cylinders, SCBA is required when levels of Phosphine are unknown, or known to exceed the short-term exposure limit (STEL; 1 ppm for 15 minutes for Phosphine). Troubleshooting assistance for a particular piece of blending equipment is addressed in the respective equipment manual which is available from the authorized VAPORPH<sub>3</sub>OS® Phosphine Fumigant distributor. Questions for problems other than those listed below, should be directed to the authorized VAPORPH<sub>3</sub>OS® Phosphine Fumigant distributor.

1. Condensation is forming on the outside of the cylinder.  
This is normal. As the fumigant is removed from the cylinder, the liquefied Phosphine boils to maintain the pressure in the cylinder gas space. This results in a chilling of the cylinder, and the condensing of moisture from the air.
2. Ice has formed on the bottom of the cylinder.  
This is normal. The liquid Phosphine that remains in the cylinder must vaporize in order to be released. If the withdrawal rate is high enough, the temperature that results from chilling can be below the freezing point for water. Instead of ambient moisture simply condensing, it freezes on the cylinder surface.
3. There is a leak at the cylinder valve. REFER TO SECTION XIV: SPILL AND LEAK PROCEDURES.
  - a) There is a leak at the cylinder valve outlet.
    - i. If the cylinder is attached to the blending equipment:  
The connection to the valve outlet might be the problem. If tightening (but not over-tightening) the outlet connection does not solve the problem, close the cylinder valve and use the blending equipment to vent the remaining fumigant in the line. Purge the equipment, then disconnect the connection to the cylinder and inspect the fitting and valve outlet for damage. If the fitting is damaged, replace it. If the valve outlet is damaged, do not use the cylinder. Install the valve outlet plug and attach a tag to the cylinder conspicuously indicating "Bad Valve Outlet" and return it.
    - ii. If the cylinder is not attached to the blending equipment:  
Check to see if the cylinder valve is fully closed. If it is fully closed and the leak continues, the cylinder should be moved to a well-ventilated area, away from personnel. Refer to Spill and Leak Procedures, Section XIV.

b) The leak is not at the cylinder valve outlet.

Assistance is required. Refer to Spill and Leak Procedures, Section XIV

4. Phosphine gas is not dispensing from cylinder.

Check to see if the cylinder is empty. Weigh the cylinder (without the cap) and compare it to the cylinder tare (empty) weight. The tare weight is stamped near the top of the cylinder and distinguished with the letters "TW". Subtract the tare weight from the measured weight. The difference is the amount of product in the cylinder. If there is a weight difference, then the cylinder has product and the outlet valve is faulty. Do not attempt to use the cylinder. Attach a tag to the cylinder indicating "bad valve" and return it to your distributor. Consult the blending equipment instructions for troubleshooting assistance.

5. Loss of CO<sub>2</sub> Supply

The blending equipment is designed to automatically shut down the flow of Phosphine gas if the Carbon Dioxide supply pressure is lost or is insufficient. Close the phosphine cylinder discharge valve and discontinue operating the blending equipment until problems with the CO<sub>2</sub> supply are resolved. Contact the CO<sub>2</sub> equipment supplier for help in troubleshooting supply problems.

6. Loss of Dilution Air

The blending equipment is designed to automatically shut down if the dilution Forced Air flow is lost or is insufficient. Close the Phosphine cylinder discharge valve and discontinue operating the blending equipment until problems with the air supply are resolved.

### **3. Application to Bulk Commodities**

#### ***a. General***

VAPORPH<sub>3</sub>OS® Phosphine Fumigant can be used to fumigate any type of storage used to hold listed bulk commodities. These include, but are not limited to bins, tanks, flat storage, and bunkers. The most important aspects of a successful fumigation, as with any fumigant, are the degree to which the space is sealed and the assurance that the minimum fumigant concentrations are maintained for the required time.

#### ***b. Develop and appropriate Fumigation Management Plan***

Refer to Section IV. G. Fumigation Management Plan.

#### ***c. Procedure for Fumigating Bulk Commodities***

1. Calculate the empty volume space to be treated.
2. Determine the target Phosphine concentration desired and the duration of the fumigation based on area fumigated, commodity type and packaging, the insect pest(s) involved, and the commodity temperature. For details, refer to Section IV.D. (Directions for Use-Dosage Guide) in this manual.
3. Calculate how much fumigant (Phosphine and CO<sub>2</sub> [if used]) will be required. If forced air is used for dilution with VAPORPH<sub>3</sub>OS® Phosphine Fumigant, check the blending unit for its adequacy for the space to be treated.
4. Determine where the fumigant will be dispensed into the space, and plan for and install required equipment.
5. Gas monitoring should be performed from outside the fumigated structure. Polyethylene tubing should be used for remote monitoring. This tubing can be run from each area of the fumigation to an outside location where gas samples can be taken safely. At least one monitoring line should be

- run in each fumigated structure. In the event of multi-floored structures or compartmentalized buildings, monitoring should be performed in all major areas of the fumigated structure. Fans can be used to help distribute gas into smaller areas and the outer reaches of these structures.
6. Isolate and seal all openings to other storage and spaces that are not intended for fumigation.
  7. Seal all openings including cracks, windows, doors, vents, eaves, hatches, loading and unloading connections and ventilation fans. Seal all penetrations used for fumigant dispensing and monitoring. Use proper safety equipment and entry procedures if confined space entry is required.
  8. Ensure that all personnel, animals, and damageable goods are clear of the space to be treated and post-fumigation placards on all points of access and any unloading penetrations.
  9. Lock all entrances to the space.
  10. Verify that all required safety equipment is available and in good working order.
  11. Notify all personnel in nearby buildings at the facility that fumigant release is about to commence.
  12. Connect the VAPORPH<sub>3</sub>OS<sup>®</sup> Phosphine Fumigant cylinders to the CO<sub>2</sub> or forced air blending equipment.
  13. Purge and leak test the blending equipment.
  14. Dispense the initial dose of blended VAPORPH<sub>3</sub>OS<sup>®</sup> Phosphine Fumigant.
  15. Periodically monitor the Phosphine concentrations within the space, using suitable gas detection equipment, to ensure that the minimum concentrations are being maintained. During and immediately after blending of VAPORPH<sub>3</sub>OS<sup>®</sup> Phosphine Fumigant with the CO<sub>2</sub> or Forced Air, the fumigation area should be monitored hourly for Phosphine concentrations until stabilized. If concentration is falling rapidly, the applicator should investigate the structure for possible leak points. Seal any leak points found. In a well-sealed structure, the Phosphine concentration should stabilize quickly and monitoring frequency can be reduced to daily measurements. The sampling frequency should be adjusted and additional VAPORPH<sub>3</sub>OS<sup>®</sup> Phosphine Fumigant blended as required to ensure the desired Phosphine concentrations are maintained during the fumigation period.
  16. Blend and dispense additional fumigant as required to maintain the desired Phosphine concentrations. At any time the dosage of phosphine should not exceed the recommended application rate.
  17. When no further fumigant is required, close all cylinder valves and isolate the CO<sub>2</sub> source if used. Depressurize and purge the blending equipment and disconnect all VAPORPH<sub>3</sub>OS<sup>®</sup> Phosphine Fumigant cylinders and CO<sub>2</sub> source if used. Ensure that the valve discharge cap is securely installed and replace the cylinder cap.
  18. Before leaving the fumigation site, re-check barricades and placards at all entrances/exits into the fumigation space and/or area under fumigation to prevent entry by unauthorized people and animals during fumigation.
  19. When the fumigation is complete, unseal the space and aerate (see VIII. AERATION OF FUMIGATED COMMODITIES and IX. E. AERATION AND REENTRY). Use suitable gas detection equipment to check both the carbon dioxide (if used) and Phosphine concentrations before allowing entry into the space. Use appropriate breathing apparatus and entry procedures to avoid undue worker exposure.

#### **Additional Considerations for Fumigating Large Quantities of Bulk Commodities:**

1. Dispensing and monitoring lines should be installed with loading, unloading and other operations in mind. If frequent fumigations are expected, permanently mounted lines should be secured within the space. If temporary lines are to be used, they should be installed so they can easily be removed at the end of the fumigation.

2. The use of additional tarpaulins or plastic sheeting atop the commodity should be considered, if there is a substantial open space above the stored product. This will help minimize the loss of Phosphine from the commodity and the total amount of fumigant required.
3. Recirculation of fumigant by specially installed small blowers is an excellent means of distributing the fumigant gas throughout the space being treated. The use of existing aeration blowers is not suggested since their capacity is often so high that it assists in the loss of the fumigant. Small commercial blowers can be used to recirculate the atmosphere within the space being treated. Blended VAPORPH<sub>3</sub>OS<sup>®</sup> Phosphine Fumigant should be dispensed into the discharge of recirculation blowers. The blowers should not be run continuously, but long enough to ensure good fumigant distribution and each time fumigant is added.
4. For large storage facilities, multiple dispensing points should be considered to assist in the distribution of the fumigant.

#### **4. Application to Space Fumigations**

##### ***a. General***

VAPORPH<sub>3</sub>OS<sup>®</sup> Phosphine Fumigant can be used to fumigate any type of space (empty or full) where listed commodities are stored or processed, except barges. These include, but are not limited to mills, warehouses, processing facilities, packaging plants and other structures. The most important aspects of a successful fumigation, as with any fumigant, are the degree to which the space is sealed and the assurance that the minimum fumigant concentrations are maintained for the required time.

Blended VAPORPH<sub>3</sub>OS<sup>®</sup> Phosphine Fumigant dispensing lines shall not be placed in or attached to commodity packages containing processed food.

##### ***b. Develop and follow an appropriate Fumigation Management***

Refer to Section IV. G. Fumigation Management Plans.

##### ***c. Procedure for Fumigating Spaces***

1. Calculate the empty volume of the space to be treated.
2. Determine the target Phosphine concentration desired and the duration of the fumigation. This should be based on the target pests and the temperature of the space or commodity.
3. Calculate how much VAPORPH<sub>3</sub>OS<sup>®</sup> (Phosphine) and CO<sub>2</sub> will be required. The CO<sub>2</sub> and air concentration in the blended mixture will be automatically controlled by the blending equipment to ensure the mixture is nonflammable.)
4. Determine where the fumigant will be dispensed into the space, and plan for and install required components. Dispensing points should not be located in or attached to processed food commodity packages. Direct the discharge toward the center of the space being treated and away from any equipment present in the fumigation space, if possible.
5. Determine the number and location of circulating fans. Low speed fans should be placed on the floor and angled upwards. A means of turning the fans off from outside the treated space should be provided.
6. Determine where the fumigant concentrations will be measured (if used) and plan for and install required gas sampling lines.
7. Identify one access door and lock all other entrances. Lock all ground level and other accessible windows if possible.

8. Except for the access door, seal all openings including cracks, windows, doors, vents, eaves, ventilation fans and points of material transfer. Seal all penetrations used for fumigant dispensing and monitoring. Isolate and seal all connections to other spaces that are not intended for fumigation.
9. Remove from the space, or protect sensitive equipment, material and food.
10. Ensure that all personnel, animals and damageable goods are clear of the space to be treated and post fumigation placards on and lock all points of access. The only exception to this is silo complexes connected by tunnels. Separate ventilation and monitoring must be in place to protect workers in adjacent areas.
11. Close, lock, seal, and placard the access door.
12. Verify that all required safety equipment is available and in good working order.
13. Notify all personnel that fumigant release is about to commence.
14. Connect the VAPORPH<sub>3</sub>OS<sup>®</sup> Phosphine cylinders and Forced Air or CO<sub>2</sub> source, to the blending equipment.
15. Purge and leak test the blending equipment.
16. Dispense the initial dose of blended VAPORPH<sub>3</sub>OS<sup>®</sup> Phosphine Fumigant.
17. Periodically monitor the Phosphine concentrations within the space, using suitable gas detection equipment, to ensure that the minimum concentrations are being maintained.
18. Blend and dispense additional fumigant as required to maintain the desired Phosphine concentrations.
19. When no further fumigant is required close all cylinder valves. Depressurize and purge the blending equipment and disconnect all VAPORPH<sub>3</sub>OS<sup>®</sup> Phosphine cylinders and Forced Air/CO<sub>2</sub> source. Ensure that the valve discharge cap is securely installed and replace the cylinder cap.
20. Before leaving the fumigation site, recheck barricades and placards at all entries into the fumigation space and/or fumigated area to prevent entry by unauthorized personnel during fumigation.
21. When the fumigation is complete, unseal the space and aerate (see VIII. AERATION OF FUMIGATED COMMODITIES and IX. E. AERATION AND REENTRY). Use suitable gas detection equipment to check both the carbon dioxide and Phosphine concentrations before allowing entry into the space. Use appropriate breathing apparatus and entry procedures to avoid undue worker exposure.
22. Remove all dispensing and gas monitoring lines.
23. Workers should be aware that some residual gas may be entrapped within the fumigated commodity container (i.e., bagged product such as SUPERSACKS). Adequate monitoring and aeration must be performed to reduce any residual Phosphine levels to below 0.3 ppm.

## **5. Application to Tarpaulin Fumigations**

### ***a. General***

VAPORPH<sub>3</sub>OS<sup>®</sup> Phosphine Fumigant can be used to fumigate stacked materials by covering the material with a tarpaulin made from plastic sheeting. This allows the fumigant to be contained to the treated material only. The most important aspects of a successful fumigation, as with any fumigant, are the degree to which the space is sealed and the assurance that the minimum fumigant concentrations are maintained for the required time.

Blended VAPORPH<sub>3</sub>OS<sup>®</sup> Phosphine Fumigant dispensing lines shall not be placed in or attached to commodity packages containing processed food.

***b. Develop and follow an appropriate Fumigation Management Plan***

Refer to Section IV. G. Fumigation Management Plans.

***c. Procedure for Tarpaulin Fumigations***

1. Since the volume of tarped materials can vary widely, it is important to make a good estimate of the volume enclosed by the tarp. Calculate the volume taken up by the material itself (palletized stacks for example) or any containers used to hold it. After tarping is complete, revise the volume estimate based on the additional empty space contained within the tarp.
2. Determine the target Phosphine concentration desired and the duration of the fumigation. This should be based on the target pests and the temperature of the material being treated.
3. Calculate how much Phosphine will be required, based on the volume calculation. Pre-blended phosphine gas (**ECO<sub>2</sub>FUME** fumigant gas) should be used for small tarpaulin fumigations.
4. Determine where the fumigant will be dispensed into the space, and plan for and install required components. Dispensing points should not be located in or attached to commodity packages or within containers.
5. Determine where the fumigant concentrations will be measured and plan for and install required gas sampling lines. Sampling points should not be located near dispensing points to avoid incorrect readings.
6. Cover the material with plastic sheeting using tape, glue or clamps to join individual sheets. If the flooring on which the material is placed is wood or other porous material, it should be covered first with plastic sheeting. Seal the plastic covering to the floor using tape, glue, sand or water “snakes”, shoveling sand or soil onto the ends of the plastic, or by other suitable means. Reinforce by tape or other means, any sharp corners or edges to reduce the risk of tearing the plastic. Plastic sheeting should be a minimum of 2-mil thickness for indoor applications however, 4 mil is preferred and is more suitable for outdoor use. Ensure that tarp penetrations for dispensing and monitoring are well sealed.
7. Placard the tarped material.
8. Verify that all required safety equipment is available and in good working order.
9. Notify all personnel that fumigant release is about to commence. For the case of indoor tarp fumigations, the area surrounding the material being treated should be monitored for Phosphine and carbon dioxide (if used) concentrations to ensure that workers are not unduly exposed. It is required that all personnel not trained or involved in execution of the fumigation be restricted from entering the area, until the work is complete. Workers under a continuous roof, connected buildings or those working near an adjacent outside wall should be vacated.
10. Connect the **VAPORPH<sub>3</sub>OS<sup>®</sup>** Phosphine Fumigant cylinders to the blending equipment.
11. Purge and leak test the blending equipment.
12. Dispense the initial dose of blended **VAPORPH<sub>3</sub>OS<sup>®</sup>** Phosphine Fumigant.
13. Periodically monitor the Phosphine concentrations within the space, using suitable gas detection equipment, to ensure that the minimum concentrations are being maintained for the required time.
14. Dispense additional fumigant as required to maintain the desired Phosphine concentrations.
15. When no further fumigant is required, close all cylinder valves. Depressurize and purge the blending equipment and disconnect all **VAPORPH<sub>3</sub>OS<sup>®</sup>** Phosphine Fumigant gas cylinders. Ensure that the valve discharge cap is securely installed and replace the cylinder cap.
16. Before leaving the fumigation site, recheck barricades and placards at all entries into the fumigation

- space and/or fumigated area to prevent entry by unauthorized personnel during fumigation.
17. When the fumigation is complete, remove the tarp and aerate as appropriate using precautions to prevent exposure to workers (see VIII. AERATION OF FUMIGATED COMMODITIES and IX. E. AERATION AND REENTRY).

### **Additional Considerations:**

1. Do not walk on tarped material once it has been sealed and fumigant has been dispensed.
2. Placard each access to the area where treatment is occurring.
3. Seal off doors, windows and other connections to adjacent areas that may be occupied and placard on the occupied side.

## **6. Application to Transport Containers and Trailers**

### ***a. General***

Railcars and containers, trucks, vans and other transport vehicles shipped piggyback by rail may be fumigated in-transit, however, aeration en-route is prohibited. It is not legal to move trucks, trailers, containers, vans, etc. over public roads or highways until they have been aerated and the warning placards removed. Notify the consignee if the commodity is to be shipped under fumigation. If the consignee is unfamiliar with proper handling of fumigated rail cars and containers fumigated in-transit, it is recommended that they be provided with the necessary information. See Section VI and VIII of this manual for recommendations concerning placarding, commodity aeration, and training of persons authorized to remove placarding.

Containers, trucks, and other transport vehicles loaded with bulk commodities, when stationary, to which VAPORPH<sub>3</sub>OS<sup>®</sup> Phosphine Fumigant may be added are treated in essentially the same way as any other storage facility. However, when transport vehicles are fumigated in-transit they require special handling, which is described below.

Blended VAPORPH<sub>3</sub>OS<sup>®</sup> Phosphine Fumigant dispensing lines shall not be placed in or attached to commodity packages containing processed food.

Trailers and containers require small amounts of fumigant. Fumigators should evaluate if cylinders of preblended ECO<sub>2</sub>FUME<sup>®</sup> fumigant gas should be used.

### ***b. Procedure for Stationery Container and Trailer Fumigation***

1. Develop and follow an appropriate Fumigation Management Plan (Refer to Section IV. G.)
2. Determine the empty volume of the trailer or container.
3. Determine the target Phosphine concentration and exposure time desired. This should be based on the target pests, the commodity temperature, and the commodity stored in the container.
4. Calculate how much fumigant (Phosphine) and CO<sub>2</sub> (if used) will be required.
5. Inspect all sidewalls, roof, floor, and doors for cracks, holes or defects. Seal all openings with tape or caulk. Particular attention should be paid to any drain holes in the floor.
6. Install the fumigant gas dispensing line and secure it to the door, wall or floor with tape.
7. Close the door and seal with tape, caulk or polyethylene sheeting to prevent gas loss.
8. Affix fumigation placards to all sides of the container or trailer.

9. Verify that all required safety equipment is available and in good working condition.
10. Notify all personnel that fumigant release is about to commence. When trailers attached to tractors and trucks are fumigated, drivers should not be allowed to enter the vehicle until fumigation has ended and the truck is aerated.
11. Purge and leak test the blending equipment.
12. Blend and dispense the predetermined quantity of VAPORPH<sub>3</sub>OS® Phosphine Fumigant into the container or trailer.
13. Before leaving the fumigation site, recheck barricades and placards at all doors into the fumigation space and/or fumigated area to prevent entry by unauthorized personnel while fumigation is in progress.
14. When the fumigation is complete, aerate as appropriate using precautions to prevent exposure to workers (See Section VIII. Aeration of Fumigated Commodities and IX.E. Aeration and Reentry). Adequate monitoring and aeration must be performed to reduce any residual Phosphine levels to below 0.3 ppm.

### ***c. Procedure for In-Transit Container and Trailer Fumigation***

Develop and follow an appropriate Fumigation Management Plan (Refer to Section IV. G.).

A Certified Applicator or trained person under his direct supervision must be responsible for adding fumigant and sealing and placarding the container or trailer for transport. The shipper and/or the fumigator must provide written notification to the receiver of the railcar, railroad boxcars, shipping containers and other vehicles that have been fumigated in-transit. A Certified Applicator or trained person under his direct supervision is responsible for ensuring that a copy of the label and Application Manual precedes or accompanies all transportation containers or vehicles that are fumigated in-transit. If the application manual is sent with the transport vehicle it must be placed securely on the outside of the vehicle. Proper handling at their destination is the responsibility of the consignee. Upon receipt of the railcar, railroad boxcars, shipping containers and other vehicles fumigated in-transit, a Certified Applicator and/or persons with documented authorized training must supervise the aeration process and removal of the placards.

### **TRAINING REQUIREMENTS FOR RECEIPT OF VEHICLES OR SHIPPING CONTAINERS FUMIGATED IN-TRANSIT**

The trained person(s) must be trained by a Certified Applicator following the EPA accepted product Application Manual, or by other training which is accepted by local or state authorities. The worker training should take place before the in-transit (fumigated) containers arrive and the training should include related instructional materials in addition to the Application Manual. When training has been completed and the employee demonstrates safety knowledge proficiency, the training date must be logged and maintained in the employee's safety training record for a minimum of three years. Refresher training must be done on an annual basis.

This training must cover the following items, each of which may be found in this manual.

1. How to aerate the vehicle and verify that it contains no more than 0.3 ppm phosphine

**OR**

2. How to transfer the commodity under fumigation to another storage area without prior aeration, to ensure that safety limits for workers and people in neighboring areas are not being exceeded during

transfer and to placard the new storage area until aeration.

3. How to determine when respiratory protection must be worn.
4. How to protect workers and nearby persons from exposure to levels above the 8-hour time weighted average (TWA) of 0.3 ppm or the 15 minute TWA short-term exposure limit (STEL) of 1.0 ppm phosphine.
5. Proper removal of placards from the vehicle or shipping container

## **7. Application To Ships (not for use on barges)**

### ***a. General***

1. Develop and follow an appropriate Fumigation Management Plan (Refer to Section IV. G.).
2. Important – shipboard, in transit ship or ship hold fumigation is also governed by U.S. Coast Guard Regulation 46 CFR 147A. *Interim regulations for shipboard fumigation*. Refer to this regulation prior to fumigation. For further information contact:

Commandant  
U.S. Coast Guard  
Hazardous Materials Standards Division  
GMSO-3  
Washington, DC 20593-0001

3. In addition to the ship fumigation procedures outlined in the following paragraphs (b, c, d, and e), applicators must follow the general procedures for fumigating bulk commodities (see IV. H. 3. b), spaces (see IV. H. 4. b), or containers (see IV.H. 6. b), as appropriate. Special instructions are also provided below (paragraph d) for handling in-transit fumigation of containers and ships. Gas circulation assistance may be needed to ensure complete penetration with VAPORPH<sub>3</sub>OS<sup>®</sup> Phosphine Fumigant for bulk commodity fumigations. Suggestions are provided under “Additional Considerations” in Section IV.H.3. b, “Application to Bulk Commodities.”

### ***b. Pre-Voyage Fumigation Procedures for In-Transit Fumigation***

1. Prior to fumigating a vessel for in-transit cargo fumigation, the master of the vessel, or his representative, and the fumigator must determine if the vessel is suitably designed and configured to allow for safe occupancy by the ship’s crew throughout the duration of the fumigation. If it is determined that the design and configuration of the vessel does not allow for safe occupancy by the ship’s crew throughout the duration of the fumigation, then the vessel will not be fumigated unless all crew members are removed from the vessel. The crew members must not be allowed to reoccupy the vessel until it has been properly aerated and a determination has been made by the master of the vessel and the fumigator that the vessel is safe for occupancy.
2. The person responsible for the fumigation must notify the master of the vessel or his representative of the requirements relating to personal protection equipment\*\* and detection equipment, and that a person qualified in the use of this equipment must accompany the vessel with cargo under fumigation. Emergency procedures, cargo ventilation, periodic monitoring and inspections, and first aid measures must be discussed with and understood by the master of the vessel or his representative.

\*\*Personal protection equipment means a NIOSH/MSHA approved air purifying full face gas-mask with a chin style mounted canister approved for phosphine, OR a NIOSH/MSHA approved supplied-air respirator with a full face piece for phosphine up to 15 ppm. Although respiratory protection is not required for CO<sub>2</sub> exposure up to 5000 ppm, a canister respirator will not provide protection from CO<sub>2</sub> at any concentration. A self-contained breathing apparatus (SCBA) must be worn and operated in a positive pressure mode when phosphine levels are above 15 ppm or at unknown concentrations.

3. Seal all openings to the cargo hold or tank and lock or otherwise secure all openings, manways, etc., that might be used to enter the hold. The overspace pressure relief system of each tank aboard tankers must be sealed by closing the appropriate valves and sealing the openings into the overspace with gas-tight materials.
4. Placard all entrances to the treated spaces with fumigation warning signs.
5. If the fumigation is not completed and the vessel aerated before the manned vessel leaves port, the person in charge of the vessel shall ensure that at least two units of personal protection equipment and one gas or vapor detection device, and a person qualified in their operation be on board the vessel during the voyage. **The VAPORPH<sub>3</sub>OS® Phosphine Fumigant cylinders and the CO<sub>2</sub> source (if used) must be disconnected and removed from the vessel before it leaves port.**
6. During the fumigation or until a manned vessel leaves port or the cargo is aerated, the person in charge of the fumigation shall ensure that a qualified person using gas or vapor detection equipment tests spaces adjacent to spaces containing fumigated cargo and all regularly occupied spaces for fumigant leakage. If leakage of the fumigant is detected, the person in charge of the fumigation shall take action to correct the leakage or shall inform the master of the vessel, or his representative, of the leakage so that corrective action can be taken.
7. The person in charge of the fumigation shall review with the master, or his representative, the precautions and procedures to be followed during the voyage.

*c. Application Procedures for Bulk Dry Cargo Vessels and Tankers*

Immediately after application of the fumigant, close and secure all hatch covers, tank tops, butterworth valves, manways, etc.

1. If the fumigation is not completed and the vessel aerated before the manned vessel leaves port, the person in charge of the vessel shall ensure that at least two units of personal protection equipment and one gas or vapor detection device, and a person qualified in their operation be on board the vessel during the voyage. **The VAPORPH<sub>3</sub>OS® Phosphine Fumigant cylinders and the CO<sub>2</sub> source (if used) must be disconnected and removed from the vessel before it leaves port.**
2. During the fumigation or until a manned vessel leaves port or the cargo is aerated, the person in charge of the fumigation shall ensure that a qualified person using gas or vapor detection equipment tests spaces adjacent to spaces containing fumigated cargo and all regularly occupied spaces for fumigant leakage. If leakage of the fumigant is detected, the person in charge of the fumigation shall take action to correct the leakage or shall inform the master of the vessel, or his representative, of the leakage so that corrective action can be taken.

#### *d. In-transit Fumigation of Containers Aboard Ships*

In-transit fumigation of transport units on ships is also governed by the U.S. Department of Transportation (DOT). RSPA 49 CFR 176.76 (h) transport vehicles, freight containers, and portable tanks containing hazardous materials and International Maritime Dangerous Goods Code P9025-1 Amdt. 30-00.

1. If the fumigation is not completed and the vessel aerated before the manned vessel leaves port, the person in charge of the vessel shall ensure that at least two units of personal protection equipment and one gas or vapor detection device, and a person qualified in their operation be on board the vessel during the voyage. **The VAPORPH<sub>3</sub>OS<sup>®</sup> Phosphine Fumigant cylinders and the CO<sub>2</sub> source (if used) must be disconnected and removed from the vessel before it leaves port.**
2. During the fumigation or until a manned vessel leaves port or the cargo is aerated, the person in charge of the fumigation shall ensure that a qualified person using gas or vapor detection equipment tests spaces adjacent to spaces containing fumigated cargo and all regularly occupied spaces for fumigant leakage. If leakage of the fumigant is detected, the person in charge of the fumigation shall take action to correct the leakage or shall inform the master of the vessel, or his representative, of the leakage so that corrective action can be taken.

#### *e. Precautions and Procedures During Voyage*

1. Using appropriate gas detection equipment, monitor spaces adjacent to areas containing fumigated cargo and all regularly occupied areas for fumigant leakage. If leakage is detected, the area should be evacuated of all personnel, ventilated, and action taken to correct the leakage before allowing the area to be occupied.
2. Do not enter fumigated areas except in an emergency. If necessary to enter a fumigated area, appropriate personal protection equipment must be used. Never enter fumigated areas alone. At least one other person, wearing personal protection equipment, should be available to assist in case of an emergency.

#### *f. Precautions and Procedures During Discharge*

If necessary to enter holds prior to discharge, test spaces directly above the cargo surface for fumigant concentration using appropriate gas detection and personal safety equipment. Do not allow entry to fumigated areas without personal safety equipment, unless fumigant concentrations are at safe levels, as indicated by a suitable detector.

## **V. PERSONAL PROTECTIVE EQUIPMENT (PPE)**

### **A. GLOVES**

It is recommended that leather work gloves or leather faced cotton gloves be used when connecting to or disconnecting VAPORPH<sub>3</sub>OS<sup>®</sup> Phosphine Fumigant cylinders from the blending equipment.

### **B. SAFETY GLASSES**

When working with pressurized equipment, safety glasses should be worn.

## **C. SAFETY SHOES**

It is recommended that steel-toed safety shoes be worn by anyone handling compressed gas cylinders.

## **D. HAND TRUCKS**

Hand trucks are the recommended means of moving individual VAPORPH<sub>3</sub>OS<sup>®</sup> Phosphine Fumigant cylinders about the fumigation site. The hand truck should be designed specifically for compressed gas cylinders and equipped with a suitable chain or strap to ensure the cylinder remains in place. Never move a VAPORPH<sub>3</sub>OS<sup>®</sup> Phosphine Fumigant cylinder without valve cap and cylinder cap in place.

## **E. RESPIRATORS**

### **1. When Respiratory Protection Must Be Worn**

NIOSH/MSHA approved respiratory protection must be worn during exposure to concentrations in excess of permitted limits or when concentrations are unknown. Respiratory protection (SCBA) must be worn during trouble shooting for leaks if the concentration of Phosphine is unknown or known to exceed the STELs for Phosphine (1 ppm for 15 minutes) and/or carbon dioxide (30,000 ppm for 15 minutes).

### **2. Permissible Gas Concentration Ranges For Respiratory Protection Devices**

A NIOSH/MSHA approved, full-face gas mask Phosphine canister combination may be used at levels up to 15 ppm. Full-face canister respirators shall not be used in Phosphine concentrations above 15 ppm Phosphine because of the presence of carbon dioxide. Although respiratory protection is not required for CO<sub>2</sub> exposure up to 5,000 ppm, a canister respirator will not provide protection from CO<sub>2</sub> at any concentration.

### **3. Requirements For Availability of Respiratory Protection**

Respiratory protection must be available at the site of application in case it is needed when applying VAPORPH<sub>3</sub>OS<sup>®</sup> Phosphine Fumigant. An adequate number of self-contained breathing apparatus (SCBA) with full facepiece and operated in pressure-demand mode must be available at the site of application. Other types of respiratory protective equipment may be used as appropriate. See the following Table.

## **NIOSH –RECOMMENDED RESPIRATORY PROTECTION FOR WORKERS EXPOSED TO PHOSPHINE GAS:**

| <u>CONDITION</u>     | <u>MINIMUM RESPIRATORY PROTECTION</u>  |
|----------------------|--|
| (Phosphine gas, ppm) |  |
| 0.3- 3               | Supplied-air respirator  |
| 7.5 or less          | Supplied-air respirator operated in a continuous-flow mode   |
| 15 or less           | Self-contained breathing apparatus with full facepiece or supplied-air respirator with a full facepiece, or air-purifying full-facepiece respirator (gas mask) with a chin-style front- or back-mounted canister |
| 50 or less           | Supplied-air respirator equipped with a full facepiece and operated in pressure-demand mode or SCBA with a full facepiece and operated in a pressure-demand mode   |
| More than 50 ppm     | Do not enter until the phosphine level is 50 ppm or less   |

## **F. NOTIFICATION REQUIREMENTS**

### 1. Authorities and on-site workers:

On an annual basis, prior to a fumigation, or more frequently if required by the Fumigation Management Plan, provide and review with local emergency planning committee officials (as defined by Emergency Planning and Community Right-to-Know Act (EPCRA) section 301(c), the MSDS, Applicator's Manual, and other relevant safety information, if available, for use in the event of an emergency.

### 2. Incidents involving these products:

Registrants must be informed of any incident involving the use of this product. Please call Dan Liebowitz at Cytec Industries Inc. (1-973-357-3460) so the registrant can report all incidents as per requirements of OSHA CFR 29.

## **VI. PLACARDING OF FUMIGATED AREAS**

The applicator must placard or post all entrances to the fumigated area or transport containers fumigated in-transit with signs in English and Spanish bearing:

1. The signal word "**DANGER/PELIGRO**" and the **SKULL** and **CROSSBONES** symbol in red.
2. The statement, "Area and/or commodity under fumigation, DO NOT ENTER/NO ENTRE".
3. The statement "This sign may only be removed after the commodity is completely aerated (contains 0.3 ppm or less Phosphine gas and 5,000 ppm or less carbon dioxide). If incompletely aerated commodity is transferred to a new site, the new site must also be placarded and workers and nearby personnel must not be exposed to more than 0.3 ppm Phosphine or 5,000 ppm carbon dioxide."
4. The date and time fumigation began and expected completion date.
5. Trade name and EPA Registration number of fumigant used.
6. Name, address, and telephone number of the applicator.

7. All entrances to a fumigated area must be placarded. Placards should be placed in advance of the fumigation in order to keep unauthorized persons away. Do not remove a placard until the treated commodity is aerated down to 0.3 ppm or less of Phosphine and 5,000 ppm or less of carbon dioxide (if used). To determine whether aeration is complete, each fumigated site or vehicle must be monitored and shown to contain 0.3 ppm or less Phosphine gas and 5,000 ppm or less of carbon dioxide (if used) in the air space around and, when feasible, in the mass of the commodity. For railcar hopper cars, placarding must be placed securely on both sides of the car near the ladders and next to or on the top hatch into which the fumigant is added.
8. A Certified Applicator or person under his direct supervision must put placards in place after determining how many are required at the container or fumigation site and where they must be placed. An exception is when a trained worker receives raw agricultural commodities under in-transit fumigation and the commodity is transferred to another container before the contents are aerated. In this case, placarding is the responsibility of the trained worker.
9. Placards can only be removed by workers under the direct supervision of a certified applicator when the structure/container/vehicle is no longer under fumigation and aeration is complete. It is recommended that the person responsible for removing the placards be familiar with the physical, chemical and toxicological properties of Phosphine and carbon dioxide. They should also be knowledgeable in how to take gas readings, exposure limits, symptoms, and first aid treatment for Phosphine and carbon dioxide poisoning.

## **VII. GAS DETECTION EQUIPMENT**

At all times there should be more than one each of Phosphine and CO<sub>2</sub> (if used) detection equipment capable of measuring at least < 0.3 ppm for Phosphine and < 5,000 ppm for CO<sub>2</sub> present at the stationary and in-transit fumigation and aeration sites. They should be periodically checked for accuracy. There are a number of devices on the market for the measurement of Phosphine gas as well as carbon dioxide levels for industrial hygiene purposes. Glass detection tubes used in conjunction with the appropriate hand-operated air sampling pumps are a widely used method. These devices are portable, simple to use, do not require extensive training and are relatively rapid, inexpensive and accurate. Electronic devices are also available for both low level and high Phosphine and carbon dioxide gas readings. The newer low-level electronic units as well as the low-level detector tubes can detect 0.01 ppm of Phosphine and are suitable for industrial hygiene monitoring. Such devices should be used in full compliance with manufacturers' recommendations.

## **VIII. AERATION OF FUMIGATED COMMODITIES**

### **A. FOODS AND FEEDS**

Tolerances for Phosphine residues have been established at 0.1 ppm for animal feeds, grains, nuts, and dates; 0.01 ppm for processed foods, dry legumes, fresh fruits and vegetables. To guarantee compliance with these tolerances, it is necessary to aerate these commodities for a minimum of 48 hours prior to offering them to the end-consumer.

A shorter holding period may be permitted if the airborne phosphine concentration is found to be less than 0.3 ppm. Commodities may be analyzed before release to consumers to ensure that phosphine levels do not exceed tolerances.

## **B. NON-FOOD COMMODITIES**

Aerate all non-food commodities to less than 0.3 ppm of Phosphine. Continue to monitor densely packed commodities carefully.

## **C. TOBACCO**

Tobacco must be aerated to less than 0.3 ppm. When plastic liners are used, longer aeration periods will probably be required to aerate the commodity down to less than 0.3 ppm. A minimum aeration period of 48 hours is required.

## **IX. APPLICATOR AND WORKER EXPOSURE**

### **A. PHOSPHINE EXPOSURE LIMITS**

Exposure to Phosphine must not exceed the 8-hour TWA of 0.3 ppm for applicators and workers during application. All persons in the treated site and in adjacent indoor areas are covered by this exposure standard. Such exposures might occur because of leakage into enclosed areas from fumigation sites or during transfer of unaerated commodity. The short-term exposure limit (STEL) is 1.0 ppm Phosphine for 15 minutes.

### **B. CARBON DIOXIDE EXPOSURE LIMITS (IF USED)**

Exposure to carbon dioxide must not exceed the 8-hour TWA of 5,000 ppm or the STEL of 30,000 ppm for applicators and workers during application. Exposure to carbon dioxide must not exceed the TLV of 5,000 ppm for any persons not associated with the application during the fumigation. All persons in the treated site and in adjacent indoor areas are covered by this exposure standard. After application is completed worker or applicator exposure must not exceed 5,000 ppm maximum concentration. Such exposures might occur because of leakage into enclosed areas from fumigation sites during transfer of unaerated commodity. An SCBA is required for any carbon dioxide concentrations exceeding the TLV or TWA.

### **C. APPLICATION OF FUMIGANT**

Because the release of VAPORPH<sub>3</sub>OS<sup>®</sup> Phosphine Fumigant is not dependent on environmental conditions such as temperature and humidity, Phosphine release is instantaneous. This instantaneous release can expose the fumigator to immediate high levels of Phosphine. If the fumigator's exposure exceeds the 8- hour TWA of 0.3 ppm of Phosphine and the TLV of 5,000 ppm (0.5% by volume) of carbon dioxide (if used), approved respiratory protection such as an SCBA must be worn. Gas concentration measurements for safety purposes must be made using suitable low-level detection equipment. See the "Industrial Hygiene Monitoring" section below. The STEL for Phosphine is 1.0 ppm for 15 minutes. The STEL for carbon dioxide is 30,000 ppm.

### **D. LEAKAGE FROM FUMIGATED SITES**

Phosphine and carbon dioxide are highly mobile and given enough time may penetrate seemingly gas tight materials such as concrete and cinder block. Therefore, adjacent, enclosed areas likely to be occupied must be monitored to ensure that significant leakage has not occurred. Sealing of the fumigated area and/or the occupied areas should be used to reduce exposure.

## **E. AERATION AND REENTRY**

If the area is to be entered after fumigation, it must be aerated until the level of Phosphine gas is 0.3 ppm or below and the level of carbon dioxide (if used) is 5,000 ppm (or 0.5% by volume) or below. The area or site must be monitored to ensure that liberation of gas from the treated commodity does not result in the development of unacceptable levels of Phosphine and carbon dioxide. Do not allow reentry into treated areas by any person before this time unless protected by an approved respirator.

## **F. HANDLING UNAERATED COMMODITIES**

Transfer of a treated commodity prior to complete aeration (including in-transit) is permissible. In the process, workers, people and animals in neighboring areas must not be exposed to Phosphine and/or carbon dioxide in excess of the permitted exposure limits. Transfer of incompletely aerated commodity via bulk handling equipment such as augers, drag conveyors and conveyor belts to a new site is permissible; however, the new storage must be placarded if it contains more than 0.3 ppm Phosphine or, when blending with CO<sub>2</sub>, 5,000 ppm of carbon dioxide. Workers who handle incompletely aerated commodity must be informed and appropriate measures must be taken (i.e., ventilation or respiratory protection) to prevent exposures from exceeding the exposure limits for Phosphine and carbon dioxide. The transfer of unaerated containers or truck trailers over public roads is prohibited.

## **G. INDUSTRIAL HYGIENE MONITORING**

At each site and operation, monitor Phosphine and carbon dioxide (if used) concentrations in all indoor and neighboring areas to which fumigators, other workers, and bystanders have had access during fumigation and aeration. Perform such monitoring in workers' breathing zones. This monitoring is performed to determine when and where respiratory protection is required. After gas concentrations have been adequately characterized for various locations, spot-check those areas to determine whether conditions have significantly changed or if an unexpected garlic-like odor is present. Record all monitoring data in an operation log or manual.

## **H. ENGINEERING CONTROLS AND WORK PRACTICES**

If initial monitoring shows that workers are exposed to concentrations in excess of the permitted exposure limits, then engineering controls (such as forced air ventilation) and/or appropriate work practices should be used (such as using personal exposure monitors) where possible to reduce exposure to below permitted limits. In any case, PPE must be worn if Phosphine and/or carbon dioxide(if used) exposure limits are exceeded.

## **X. SAFE HANDLING OF COMPRESSED GASES IN CONTAINERS**

The following are excerpts from the Compressed Gas Association (CGA) Pamphlet P-1 "Safe Handling of Compressed Gases in Containers". These are provided to assist the user with the more important aspects of cylinder handling. It is recommended that the user be familiar with all aspects of this pamphlet.

1. The user is responsible for the safe use of the container and its contents and for returning the container to the gas manufacturer or distributor in the same safe condition as it was received.
2. The user shall not modify, tamper with, obstruct, remove or repair any part of the cylinder or the container valve or the valve protection device. Maintenance of the container shall be performed only by trained personnel under the direction of the container owner or an authorized representative.
3. The prescribed stamped marking on the container shall be made and kept in a legible condition. The user shall not add, remove or alter any of these markings.

4. The labels applied by the gas manufacturer to identify the container contents shall not be defaced or removed by the user.
5. Compressed gas containers shall not be exposed to temperature extremes. High temperatures may result in excessive cylinder pressure. Never apply a flame or heat directly to any part of a compressed gas container or allow it to come in contact with an electrically energized system. High temperatures may also damage the physical integrity of the container. If ice or snow accumulates on a container, thaw at room temperature, or with water at a temperature not exceeding 125°F (51.7°C).
6. Leaking or defective containers shall not be offered for shipment. Consult the gas supplier for advice under these circumstances.
7. Any damage that might impair the safety of the container shall be called to the attention of the gas supplier before returning the container.
8. Where valve outlet caps and/or plugs are provided by the gas supplier, the user shall keep the device on the valve outlet at all times, except when containers are secured and connected to dispensing equipment. Gas-tight valve outlet caps and plugs serve the purpose of containing any residual product and in accordance with the provisions of 49 CFR 173.40 and CSA B340, are mandatory for poison gas containers. The gas-tight valve outlet cap or plug must be checked and tightened securely before return shipment to the gas supplier.
9. The cylinder valve shall be kept closed at all times (charged or empty) except when the cylinder is in use. Do not use tools such as wrenches and hammers in attempting to open or close valves.
10. Users of compressed gas containers shall ensure that they are not rolled in the horizontal position or dragged. A suitable hand truck, forklift truck, cylinder pallet system or similar material-handling device should be used with the container properly secured to the device. Never lift containers by using the container cap or magnets.
11. Caution should be used when handling cylinders to guard against dropping or permitting them to violently strike against each other and other surfaces.
12. The transfer of compressed gases from one cylinder to another should only be performed by the gas supplier or by personnel who are trained and qualified with the proper transfill equipment and written operating procedures, and who are familiar with the precautions necessary to avoid the hazards of the product being transfilled and with the procedures necessary to comply with all government standards and regulations. Detailed written operating instructions including equipment inspections and maintenance procedures should be provided by the supplier of the transfill equipment and rigorously followed.
13. Cylinder valve connections that do not fit shall not be forced.
14. Gas tight connections including piping, regulators and other apparatus shall be kept gas tight to prevent leakage. This can be confirmed by the use of a compatible leak test solution or an appropriate leak detection instrument. DO NOT tighten connections or leaking fittings or attempt other repairs while the system is under pressure.
15. Prior to disconnecting a cylinder from dispensing equipment, the cylinder valve shall be closed and the dispensing equipment relieved of pressure.
16. The transportation of compressed gas cylinders in unsuitable vehicles or in closed-bodied vehicles can present serious safety hazards and should be discouraged. Refer to CGA PS-7, CGA Position Statement on the Safe Transportation of Cylinders in Vehicles, for additional guidance. Shipping compartments should be adequately ventilated.
17. An emergency response plan shall be in place wherever compressed gas containers and products are used, handled, stored, or disposed of, according to 29 CFR 1910.120. Only trained personnel shall respond to an emergency situation involving a compressed gas container or product. Personnel shall be promptly evacuated from the immediate area in danger and kept up wind at sufficient distance to avoid any inhalation or contact with potentially hazardous products until safe reentry can be ensured.

18. Before using a gas, read the label and material safety data sheet for information about the material. Exposure to toxic gases shall be kept as low as possible but in no case should concentrations exceed the exposure levels established by the Occupational Safety and Health Administration.

## **XI. STORAGE OF CYLINDERS**

### **A. GENERAL**

The first consideration when planning a storage area for VAPORPH<sub>3</sub>OS® Phosphine Fumigant cylinders is the safety needs of the local authorities. It is important that emergency response professionals are aware of all hazardous materials stored in their jurisdiction. They should be provided with an MSDS and detailed information on the quantities of product stored and the nature and location of the storage area.

### **B. EMERGENCY RESPONSE PLAN**

A clearly defined emergency response plan should be developed for the site. This plan should define procedures and outline responsibilities in addressing emergency situations involving VAPORPH<sub>3</sub>OS® Phosphine Fumigant. All site personnel should be trained in the plan and it should be practiced periodically.

Proper handling procedures as outlined in this manual must be followed. Storing cylinders with the valve discharge cap securely in place will minimize the potential for leaks. Outside storage of cylinders in a secure, well-ventilated, and preferably covered area is recommended. See Part D. of this section for further information.

### **C. INDOOR STORAGE**

The storage of poison gases in occupied spaces is not recommended. However, indoor storage in a separate building with no other occupancy is suitable. Add security (locks) for the building. The building should be of non-combustible construction (1 hour fire rating), adequately ventilated and equipped with a continuous Phosphine monitoring and alarm system that is activated at the TLV of 0.3 ppm. Operating personnel must not enter a building, when the alarm is activated, without wearing a SCBA with full facepiece and operated in pressure-demand mode. In some jurisdictions, the indoor storage of toxic gases is prohibited.

### **D. OUTDOOR STORAGE**

It is recommended that both full and used VAPORPH<sub>3</sub>OS® Phosphine Fumigant cylinders be stored outdoors in a dedicated and properly designed and labeled storage area. The following are recommended for outdoor storage:

1. A firm and level surface, preferably reinforced concrete, well drained.
2. Chain link fence topped with three strands of barbed wire, with gate and lock.
3. Covered, if snow accumulation is likely to cause handling problems. Non-combustible construction.
4. Shaded, if high temperatures are expected. Non-combustible construction.
5. Protected from vehicle traffic.
6. A means of securing all cylinders.
7. Away from building ventilation intakes.

8. Equipped with a windsock to indicate wind direction.

## **E. TEMPERATURE LIMITATIONS**

VAPORPH<sub>3</sub>OS<sup>®</sup> Phosphine Fumigant cylinders should never be stored where the temperature will exceed 125 °F (51.7 °C). Low temperatures will not affect VAPORPH<sub>3</sub>OS<sup>®</sup> Phosphine Fumigant.

## **F. SECURING CYLINDERS**

Cylinders must be stored in an upright position and protected from falling. Protection against falls can include the use of cylinder pallets with straps, walls and securing chains, or pens constructed from steel handrail or like construction.

## **G. LABELLING OF STORAGE**

The labeling of the VAPORPH<sub>3</sub>OS<sup>®</sup> Phosphine Fumigant cylinder storage area should take into account the needs of a variety of organizations. These should include, but not be limited to corporate policy, insurance carrier, Occupational Safety and Health Administration (OSHA), Right to Know and local emergency response professionals. As a minimum, it is suggested that the storage be clearly marked with the following signs:

1. Danger, Poison (with skull and crossed bones) placard
2. Flammable placard
3. Authorized Personnel Only
4. NFPA Hazard Identification Symbols

The National Fire Protection Association (NFPA) developed NFPA Hazard Identification Symbols. This standardized symbol system is designed to provide, at a glance, information regarding the health, fire, and reactivity hazards associated with hazardous materials. The following are the hazard categories and degree of hazard for VAPORPH<sub>3</sub>OS<sup>®</sup> Phosphine Fumigant:

| <b>Category</b> | <b>Degree of Hazard</b> |
|-----------------|-------------------------|
| Health          | 3                       |
| Flammability    | 4                       |
| Reactivity      | 1                       |

Materials to properly label the storage area in compliance with NFPA standards can be purchased through most safety supply companies.

NOTE: When using the NFPA Hazard Identification System, the characteristics of all hazardous materials stored in a particular area must be considered. The local fire protection district should be consulted for guidance on the selection and placement of such signs.

## **XII. TRANSPORT**

### **A. GENERAL**

VAPORPH<sub>3</sub>OS<sup>®</sup> Phosphine Fumigant is classified as a poison gas and flammable gas by the United States Department of Transportation (DOT) and it shall only be transported in accordance with DOT regulations. All

persons involved in the transport of or the preparation of cylinders for transport should be trained in and familiar with the specifications of 49 CFR (Code of Federal Regulations).

## B. TRANSPORT DESIGNATIONS

The following transport designations apply to VAPORPH<sub>3</sub>OS<sup>®</sup> Phosphine Fumigant:

|                         |                                  |
|-------------------------|----------------------------------|
| Proper Shipping Name:   | Phosphine                        |
| Hazard Class:           | 2.3                              |
| Subsidiary Class        | 2.1                              |
| Identification Number:  | UN 2199                          |
| Shipping Label:         | Poison Gas<br>Flammable Gas      |
| Additional Description: | Poison Inhalation Hazard, Zone A |

## C. TRANSPORT REQUIREMENTS

### 1. Package Preparation

VAPORPH<sub>3</sub>OS<sup>®</sup> Phosphine Fumigant cylinders shall not be transported unless:

- The cylinder valve is fully closed.
- The gas tight outlet cap is secured on the valve outlet.
- The cylinder cap is secured.
- The cylinder has a readable, proper shipping label.

### 2. Cylinder Contents

Used VAPORPH<sub>3</sub>OS<sup>®</sup> Phosphine Fumigant cylinders can still contain residual gas, and shall be offered for transport and transported as if they are full. Check with your distributor if you have questions about shipping VAPORPH<sub>3</sub>OS<sup>®</sup> Phosphine Fumigant cylinders.

### 3. Documents

Proper documentation is required by law for the transport of any hazardous material. The documentation accompanying the shipment of Phosphine (whether full, partially full, or empty) must include the labeling, a bill of lading, placard, and the MSDS. The documents must clearly identify the quantity and nature of all hazardous materials being transported or offered for transport by a second party. All persons generating such documents should be trained in their preparation.

### 4. Vehicle Loading

VAPORPH<sub>3</sub>OS<sup>®</sup> Phosphine Fumigant cylinders shall only be loaded into unoccupied spaces of vehicles. All cylinders shall be secured from movement during transport.

### 5. Vehicle Markings

Vehicles transporting VAPORPH<sub>3</sub>OS<sup>®</sup> Phosphine Fumigant shall be placarded in accordance with table I of 172.504 of 49 CFR. Consideration should be made for other hazardous materials that are concurrently being transported. Proper placarding should take into account all hazardous materials on board.

## **6. Use of Common Carriers**

Shipment of VAPORPH<sub>3</sub>OS® Phosphine Fumigant cylinders by common carrier is permitted, provided the carrier meets certain criteria. Contact an authorized VAPORPH<sub>3</sub>OS® Phosphine Fumigant distributor for an approved list of common carriers.

## **7. Driver Qualifications**

Anyone operating a vehicle that is carrying hazardous materials must be in possession of a current Commercial Drivers License (CDL) with Hazardous Material Endorsement.

## **XIII. DISPOSAL**

Once used, VAPORPH<sub>3</sub>OS® Phosphine Fumigant cylinders are to be returned only to an authorized distributor or their designated point of return. This applies to all cylinders, regardless of the quantity of material remaining in the package. Disposal of the cylinder contents is prohibited. If the cylinder is partially full do not release the remaining gases; just return the cylinder to authorized distributor.

## **XIV. SPILL AND LEAK PROCEDURES**

### **A. GENERAL**

All releases can produce high levels of toxic Phosphine gas, and therefore, attending personnel must wear a SCBA with full facepiece and operated in a pressure demand mode when the concentration of Phosphine gas is unknown. If the concentration is known, other NIOSH/ MSHA approved respiratory protection must be worn.

This material is spontaneously flammable in air and may form an explosive mixture in air. In case of fire, stop flow of gas if without risk. Use water spray, alcohol foam, carbon dioxide or dry chemical to extinguish fires. Use water to keep cylinders cool.

### **B. WHAT TO DO**

In the event of an accidental release, evacuate the area immediately. Only trained emergency responders should attempt a response into the leak area. If it is possible to shut off the source of the leak from a remote area, it should be done. Otherwise, evacuate the area and call for assistance.

### **C. WHO TO CALL**

CYTEC operates a 24-hour Emergency Response and Incident Management System (ERIM). For emergencies involving spills, call CHEMTREC: 1-800-424-9300. For emergencies involving leak, fire or exposure, call 911 or local Fire and Rescue or Cytec's Emergency Phone No. 1-800-424-9300. Outside the US or Canada call 703-527-3887.

### **D. EMERGENCY RESPONDERS**

All emergency responses should be made in level B protection, which includes neoprene, butyl rubber or PVC, gloves; Seranex coated Tyvek suit, rubber boots and an air-supplied respirator.