

RESTRICTED USE PESTICIDE

DUE TO ACUTE INHALATION TOXICITY OF HIGHLY TOXIC PHOSPHINE (HYDROGEN PHOSPHIDE, PH₃) GAS

For retail sale to Dealers and Certified Applicators only.

For use by Certified Applicators or persons under their direct supervision, and only for those uses covered by the Certified Applicator's certification. Refer to the directions in this applicator manual for requirements of the physical presence of a Certified Applicator.

APPLICATION MANUAL FOR ECO₂FUME[®] Fumigant Gas

A phosphine-containing fumigant for use in controlling pests in listed raw agricultural commodities, processed foods, stored tobacco, animal feeds, and nonfood products. Not for use in barges. Refer to the Application Manual for a list of commodities and pests controlled.

	By Weight
ACTIVE INGREDIENTS: Phosphine Gas (PH ₃).....	2%*
OTHER INGREDIENTS:	98%
TOTAL	100%

* 2.6% by volume



**KEEP OUT OF REACH OF CHILDREN
DANGER - POISON – PELIGRO**



PELIGRO AL USUARIO: Si usted no lee ingles, no use este producto hasta que la etiqueta se le haya sido explicado ampliamente
(TO THE USER: If you cannot read English, do not use this product until the label has been fully explained to you.)

FIRST AID

Symptoms of exposure to this product are headache, dizziness, nausea, difficult breathing, vomiting and diarrhea. In all cases of overexposure, get medical attention immediately. Take victim to doctor, hospital or emergency treatment facility. Have a copy of the Application Manual with you when calling a poison control center, doctor, or going for treatment.

If Inhaled	<ul style="list-style-type: none">• Move person to fresh air• If person is not breathing, call 911 or an ambulance, then give artificial respiration, preferably mouth-to-mouth if possible.• Call a poison control center or doctor for further treatment advice.
If on Skin	<ul style="list-style-type: none">• May cause frostbite to unprotected skin upon contact with dispensing equipment while gas is discharged rapidly.• Take off contaminated clothing and allow clothes to aerate in ventilated room prior to laundering.• Call a poison control center or doctor for treatment advice.
If in Eyes	<ul style="list-style-type: none">• Hold eye open and rinse slowly and gently with cool water for 15-20 minutes in case of freezing or cryogenic "burns." Do not rinse eyes with hot or even tepid water.• Remove contact lenses, if present, after the first 5 minutes, then continue rinsing.• Call a poison control center or doctor for treatment advice.• Never introduce oil or ointment into eyes without medical advice.

SEE SIDE PANEL OF LABEL FOR ADDITIONAL PRECAUTIONARY STATEMENTS

CYTEC Industries Inc. West Paterson, NJ 07424 USA

Emergency Phone: 1-800/424-9300 or 703/527-3887

EPA Registration No. 68387 -7

EPA Establishment No. 68387-CAN-1

Net Contents: 68.3 lbs (31 kg)

EVERY SHIPMENT OF CYLINDERS IS ACCOMPANIED BY AN APPROVED APPLICATION MANUAL. READ THE ENTIRE LABEL AND APPLICATION MANUAL BEFORE USE. ALL PARTS OF THE LABEL AND APPLICATION MANUAL ARE EQUALLY IMPORTANT FOR SAFE AND EFFECTIVE USE OF THIS PRODUCT. CONSULT WITH YOUR STATE LEAD PESTICIDE REGULATORY AGENCY TO DETERMINE REGULATORY STATUS, REQUIREMENTS, AND RESTRICTIONS FOR FUMIGATION USE IN THAT STATE. CALL CYTEC INDUSTRIES INC. (1-905/374-5828) IF YOU HAVE ANY QUESTIONS OR DO NOT UNDERSTAND ANY PART OF THE PRODUCT LABEL OR APPLICATION MANUAL.

REFER TO THE APPLICATION MANUAL FOR DETAILED PRECAUTIONS, RECOMMENDATIONS AND DIRECTIONS FOR USE.

WARRANTY

Seller warrants that the product conforms to its chemical description and when used according to label directions under normal conditions of use, it is reasonably fit for the purpose stated on the label. Seller makes no other warranty, either expressed or implied, and buyer assumes all risk should the product be used contrary to label instructions.

[12/27/05]

APPLICATION MANUAL
FOR
ECO₂FUME[®] Fumigant Gas

TABLE OF CONTENTS

I. INTRODUCTION	7
A. PRODUCT DESCRIPTION	7
B. PRODUCT PACKAGING	7
1. Packaging	7
2. Dispensing Equipment	8
C. PHOSPHINE AND CARBON DIOXIDE	9
D. ENVIRONMENTAL FATE	9
II. SAFETY REQUIREMENTS	9
A. GENERAL	9
B. SECURING CYLINDERS	10
C. POISON GAS HAZARDS – LEAK DETECTION AND REPAIR	10
1. Dispensing Equipment	10
2. Storage Structures	12
D. COMPRESSED GAS HAZARDS	12
1. Gas Discharge	12
2. Temperature	12
3. Residual Pressure	12
4. Liquid Expansion	13
III. PRECAUTIONARY STATEMENTS	13
A. HAZARDS TO HUMANS AND DOMESTIC ANIMALS	13
B. NOTE TO PHYSICIAN - THIS IS PHOSPHINE; IT IS NOT PHOSGENE	13
C. ENVIRONMENTAL HAZARDS	14
D. PHYSICAL AND CHEMICAL HAZARDS	14
IV. DIRECTIONS FOR USE	15
A. GENERAL	15
B. EFFICACY	16
C. USE PATTERN	16
1. PESTS	16
2. COMMODITIES	16
D. DOSAGE GUIDE	18
E. EXPOSURE GUIDELINES	19
F. SEALING	20
G. FUMIGATION MANAGEMENT PLANS	20
1. Guidance for Preparation of a Fumigation Management Plan	21

2.	A Checklist Guide for a Fumigation Management Plan	21
H.	APPLICATION PROCEDURES	24
1.	General Statement	24
2.	Equipment Specification and Use	24
3.	APPLICATION TO BULK COMMODITIES	29
4.	APPLICATION TO SPACE FUMIGATIONS	30
5.	APPLICATION TO TARPAULIN FUMIGATIONS	32
6.	APPLICATION TO TRANSPORT CONTAINERS AND TRAILERS	33
7.	APPLICATION TO SHIPS (not for use on barges)	35
8.	SPOT FUMIGATION APPLICATION	38
V.	PERSONAL PROTECTIVE EQUIPMENT (PPE)	41
A.	GLOVES	41
B.	SAFETY GLASSES	41
C.	SAFETY SHOES	41
D.	HAND TRUCKS	41
E.	RESPIRATORS	41
F.	NOTIFICATION REQUIREMENTS	42
VI.	PLACARDING OF FUMIGATED AREAS	43
VII.	GAS DETECTION EQUIPMENT	43
VIII.	AERATION OF FUMIGATED COMMODITIES	43
A.	FOODS AND FEEDS	44
B.	NON-FOOD COMMODITIES	44
C.	TOBACCO	44
IX.	APPLICATOR AND WORKER EXPOSURE	44
A.	PHOSPHINE EXPOSURE LIMITS	44
B.	CARBON DIOXIDE EXPOSURE LIMITS	44
C.	APPLICATION OF FUMIGANT	44
D.	LEAKAGE FROM FUMIGATED SITES	45
E.	AERATION AND REENTRY	46
F.	HANDLING UNAERATED COMMODITIES	46
G.	INDUSTRIAL HYGIENE MONITORING	46
H.	ENGINEERING CONTROLS AND WORK PRACTICES	46
X.	SAFE HANDLING OF COMPRESSED GASES IN CONTAINERS	46
XI.	STORAGE OF CYLINDERS	48
A.	GENERAL	48
B.	EMERGENCY RESPONSE PLAN	48
C.	INDOOR STORAGE	48
D.	OUTDOOR STORAGE	48
E.	TEMPERATURE LIMITATIONS	49
F.	SECURING CYLINDERS	49

<i>XII.</i>	<i>TRANSPORT</i>	<i>50</i>
A.	GENERAL	50
B.	TRANSPORT DESIGNATIONS	50
C.	TRANSPORT REQUIREMENTS	50
1.	Package Preparation	50
2.	Cylinder Contents	50
3.	Documents	50
4.	Vehicle Loading	50
5.	Vehicle Markings	51
6.	Use of Common Carriers	51
7.	Driver Qualifications	51
<i>XIII.</i>	<i>DISPOSAL</i>	<i>51</i>
<i>XIV.</i>	<i>SPILL AND LEAK PROCEDURES</i>	<i>51</i>
A.	GENERAL	51
B.	WHAT TO DO	51
C.	WHO TO CALL	51
D.	EMERGENCY RESPONDERS	51

I. INTRODUCTION

A. PRODUCT DESCRIPTION

ECO₂FUME[®] is a cylinderized source of phosphine. A mixture of phosphine and carbon dioxide gases, it is packaged in compressed gas cylinders. Phosphine makes up 2 percent (by weight) of the product. ECO₂FUME[®] cylinders contain carbon dioxide as liquefied gas under pressure. Pressurized carbon dioxide serves as a propellant for delivering the product and may contribute to the effectiveness of the product as a fumigant by helping to quickly disperse phosphine into the space to be fumigated. A poisonous gas, carbon dioxide retards flammability.

Phosphine and carbon dioxide are both gases that, under sufficient pressure, can exist in a liquid state. It is this “liquefied gas” that is stored in the cylinder. The product is withdrawn from the cylinder as a liquid, but dispensed as a gas. In expanding from a liquid to a gas, it increases in volume by hundreds of times. Proper dispensing equipment is necessary to ensure a safe and effective fumigation.

Unlike metallic phosphide fumigants, phosphine is not generated through a chemical reaction and its release is instantaneous. The choice of dispensing methods will depend on the type and duration of the fumigation planned.

B. PRODUCT PACKAGING

1. Packaging

ECO₂FUME[®] is packaged in a steel compressed gas cylinder, designed, manufactured, maintained and filled in compliance with regulations established by the United States Department of Transportation (DOT). The product flows to the dispensing equipment through the cylinder outlet valve, which is equipped with a “dip tube”. This tube extends to the bottom of the cylinder to facilitate the withdrawal of the liquefied gas mixture.

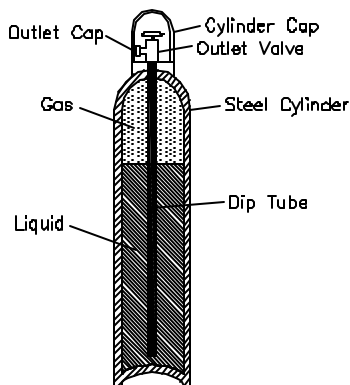

Representative Package

Overall Height: 60 inches
Diameter: 9 1/4 inches
Material: Steel
Empty Weight: 138 pounds
Product Weight: 68.34 pounds
 1.34 pounds phosphine
 67 pounds carbon dioxide

ECO₂FUME[®]

Fumigant Gas

As liquid is withdrawn from the cylinder, some of the product vaporizes to fill the remaining space in the cylinder. Through this vaporization, the cylinder pressure is maintained.

The valve outlet fitting is a CGA350, which was established by the Compressed Gas Association (CGA). The valve outlet is protected by a threaded gas-tight outlet cap, which must be secured whenever the cylinder is not in use. Attach only CYTEC provided (or approved) dispensing equipment to the cylinder valve outlet to dispense ECO₂FUME[®] at the time of fumigation. Use of any other dispensing equipment is prohibited.

Most compressed gas cylinder valves are equipped with a safety device that releases the cylinder contents due to fire exposure or overpressurization. Because ECO₂FUME[®] is a poisonous gas, DOT regulations prohibit the use of such a device.

Each cylinder is supplied with a cylinder cap, which is designed to protect the outlet valve. This cap must be secured whenever a cylinder is not in use. It is unlawful to transport an ECO₂FUME[®] cylinder without the valve outlet cap and the cylinder cap securely in place.

ECO₂FUME[®] cylinders can only be refilled through authorized distributors. They can be filled countless times within a five year period. Every five years, however, the cylinder is required by law to be tested by a qualified facility.

2. Dispensing Equipment

A typical ECO₂FUME[®] dispensing unit (see diagram on next page) uses a heating vaporizer to provide the energy required to vaporize the liquid fumigant. This regulator is limited to a dispensing rate of approximately 24 pounds of ECO₂FUME[®] per hour. The equipment is designed for a service pressure up to 3000 psig. From the cylinder, the liquid mixture flows down a flexible hose or pigtail through a filter and into a heater. The heater is thermostatically controlled. Exiting the heater valve ECO₂FUME[®] gas flows through an actuated valve that can be used for emergency shutdown purposes. ECO₂FUME[®] gas then flows through a gas regulator that drops the pressure down to less than 100 psig. The pressure is further reduced to near ambient, exit the flow control valve. A diaphragm valve is used to control the gas flow at any desired value up to 100 liters/minute as indicated by the flow rotameter. The standard dispensing unit utilizes a heater that provides 1000 watts of power that can vaporize a maximum of 100 l/min. Lower rotameter ranges are possible. ECO₂FUME[®] regulator assemblies, equipped with basic features, are available through authorized ECO₂FUME[®] distributors. Multiple dispensers may be used together to achieve higher fumigant flows than available through a single dispensing unit and custom equipment can be developed for specific types of applications.

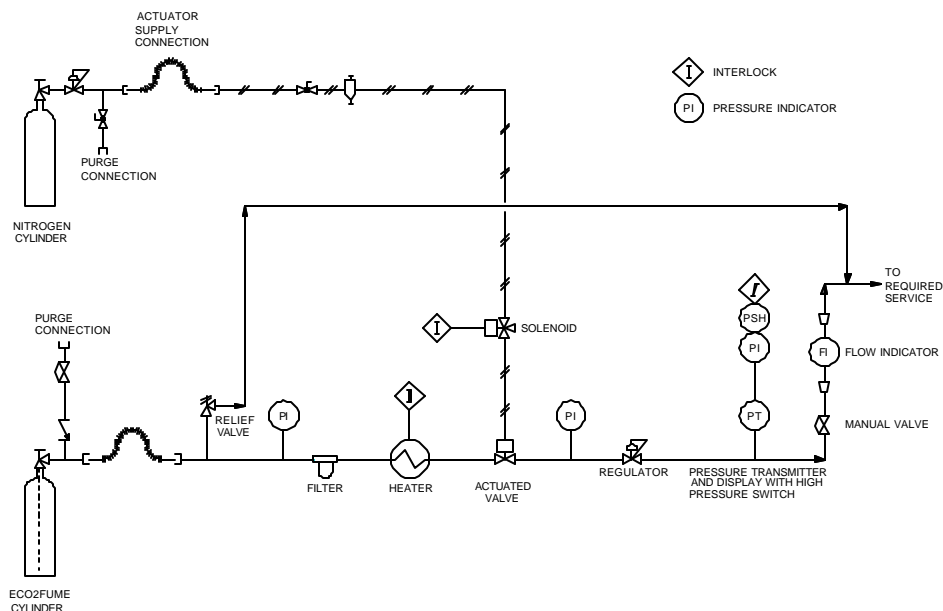

Diagram of a Representative Type of ECO₂FUME[®] Dispensing Equipment

C. PHOSPHINE AND CARBON DIOXIDE

Phosphine is a colorless gas, which is toxic to insects, humans and other forms of animal life. It is very mobile with a high vapor pressure. Thus, the penetrating capability of phosphine is great. The combination of high molecular activity, vapor pressure and toxicity to insects at low dosages accounts for its wide acceptance as a fumigant.

Carbon dioxide is colorless, non-flammable gas, which at elevated concentrations is toxic. For worker safety, the monitoring for carbon dioxide and phosphine gas is required and suitable breathing apparatus used. Sometimes phosphine may have an odor due to the presence of impurities in the product; however, this odor cannot always be relied upon as an adequate indicator of phosphine exposure.

*** ECO₂FUME[®] does not have an expiration date. Contact CYTEC Industries Inc. for any questions ***

D. ENVIRONMENTAL FATE

ECO₂FUME[®] is a volatile gaseous mixture. The environmental fate is affected by being dispersed, diluted and decomposed in ambient air after aeration from fumigated commodities where it is present in rapidly decaying low concentrations that are oxidized to non-toxic degradation products.

On airing the commodity after fumigation the volatile gaseous phosphine is dispersed to the atmosphere where it decomposes. On irradiation with UV-light, phosphine reacts with the oxygen in the atmosphere in the presence of water vapor to produce traces of H₃PO₄ (phosphoric acid). Phosphine is only moderately soluble in water, 26 cc in 100 cc of water at 17° C, in which it gradually decomposes into phosphorus, hydrogen, and the lower hydrides of phosphorus.

II. SAFETY REQUIREMENTS

ECO₂FUME[®] is a restricted use product for retail sale and use only by certified applicators and people under their direct supervision.

A. GENERAL

1. Carefully read the label and Application Manual and follow instructions explicitly.
2. Never work alone when applying fumigant from within the storage structure or aerating commodities after the fumigation is over.
3. Never allow untrained personnel to handle ECO₂FUME[®].
4. The use of respiratory protection may be required as described in Section V. E. of this manual.
5. Post ECO₂FUME[®] fumigation placards on fumigated areas, including all entrances/ exits. See Section VI for specific wording that must appear on these placards. Ensure that no personnel are inside or near to any of the structures to be fumigated prior to initiating fumigation.
6. Notify appropriate owners, employees, and/or operators at the facility where the fumigation will occur and provide relevant safety, health, and environmental information to local fire and rescue officials annually for use in the event of an emergency.

7. Worker exposure to phosphine must not exceed the 8-hour Time-Weighted Average (TWA) of 0.3 ppm during application or a maximum concentration of 0.3 ppm after application is completed. This includes reentry into a structure.
8. Worker exposure to carbon dioxide must not exceed the Threshold Limit Value (TLV) of 5,000 ppm (0.5 % by volume) at any time, either during or after application.
9. Workers required to use SCBA should be assessed for impaired pulmonary function prior to initial use and at least annually thereafter. Any employees found to have impaired pulmonary function should be referred for medical attention.
10. Protect or remove materials containing metals such as copper, silver, gold and their alloys and salts from corrosive exposure to phosphine.
11. Do not connect cylinders to dispensing equipment until all fumigation notice placards have been posted and the space to be fumigated is clear and secured.
12. Wear protective clothing as described in Section V. Respiratory protection requirements are also discussed in Section V.
13. The perimeter of the fumigation area, especially downwind, must be monitored to ensure that phosphine and carbon dioxide concentrations are kept within acceptable levels outside the fumigation area. Large leaks must be repaired to minimize loss of fumigant and reduce risk of exposure to bystanders and/or occupants of nearby buildings.

B. SECURING CYLINDERS

Cylinders must be secured upright at all times to prevent their being inadvertently knocked over. When cylinder is not connected to dispensing equipment, the valve cap and cylinder cap must be securely installed.

C. POISON GAS HAZARDS – LEAK DETECTION AND REPAIR

Because ECO₂FUME[®] is comprised of poisonous gases, care must be taken to avoid direct exposure. Appropriate procedures must be followed to detect and repair leaks in dispensing equipment and structures. These are discussed below. Also, see section XIV. of this manual, “SPILL AND LEAK PROCEDURES.”

1. Dispensing Equipment

Although the dispensing equipment is designed to contain the gas, small leaks can occur. A phosphine detector must be used at the beginning of each application to check the integrity of the equipment and any leaks must be corrected immediately. Nitrogen or carbon dioxide should be used to pressurize and leak check equipment with soap solution prior to use in the field.

If any leak is encountered while using ECO₂FUME[®] clear the immediate area of all personnel.

Only persons who are wearing a self-contained breathing apparatus (SCBA) with full facepiece and operated in pressure-demand mode or its equivalent are permitted in the area to address the leak. Once the leak has been stopped, the area must be thoroughly ventilated and the air tested with a phosphine detector. Only after the phosphine level has dropped below the eight-hour TWA of 0.3 ppm or the Short Term Exposure Limit (STEL) of 1 ppm for 15 minutes, are unprotected personnel permitted to enter.

If a cylinder leak is detected, refer to section IV.H. 2.g. 3) of this manual for guidance on troubleshooting. Further troubleshooting assistance for a particular piece of dispensing equipment is addressed in the respective equipment manual.

2. Storage Structures

To reduce the potential for leakage, careful attention should be given to inspection of the storage structure and proper sealing prior to fumigation. Refer to the DIRECTIONS FOR USE, sections IV A. (“GENERAL”) and IV F. (“SEALING”) in this manual, for related guidance.

The perimeter of the fumigation area, especially downwind and in adjacent or nearby buildings, must be monitored to ensure that phosphine and carbon dioxide concentrations are kept within acceptable levels outside the fumigation area. This involves walking around the structure with a personal monitoring device to determine whether excessive amounts of fumigant are escaping.

If a high level of phosphine is detected outside the fumigation area, the addition of fumigant must be stopped. Large leaks must be repaired to minimize loss of fumigant and reduce risk of exposure to bystanders and/or occupants of nearby buildings. Appropriate personal protective equipment must be worn when sealing leaks. These repairs must be made from the exterior of the structure whenever possible. If it is necessary to seal a leak from the interior of the structure, the applicator must follow all proper procedures for confined space entry (for details see IV. A. 2. and 3. under Directions for Use and IX.. E. under Aeration and Reentry) including wearing SCBA with full face piece and operated in pressure-demand mode.

D. COMPRESSED GAS HAZARDS

ECO₂FUME[®] cylinders and dispensing equipment can achieve pressures of over 1000 pounds per square inch. Because of this high pressure, care must be taken to avoid unintentional releases of the product.

1. Gas Discharge

The release of high-pressure gas can be forceful and there is potential for personal injury. High-speed discharge from unsecured flexible components such as hoses or tubing can result in a whipping action. The gas released can also propel small objects in the area. Such airborne objects can injure the eyes and bodies of people in the area.

2. Temperature

The rapid discharge of ECO₂FUME[®] through fast dispensing equipment will result in a chilling effect on parts of the equipment and cylinders. This thermodynamic effect can create temperatures low enough to cause frostbite if touched by unprotected skin. While this chilling is typically evidenced by the formation of ice on the equipment and cylinders, the cold hazard may exist without the formation of ice.

3. Residual Pressure

The chilling of cylinders is the result of the liquefied gas mixture boiling to maintain the pressure in the gas space of the cylinder.

A small amount of dry ice (solid carbon dioxide) may form in the cylinder when the product is dispensed very quickly and the liquid product level falls below the bottom of the dip tube. The pressure in a cylinder that has formed dry ice will be very low. When the cylinder is allowed to warm, this ice will again turn to liquid or gas and the pressure in the cylinder will rise accordingly. For this reason, all cylinders must be treated as if they contain high-pressure gas. Cylinder valves should always be closed before disconnecting the dispensing equipment.

Prior to the dismantling of ECO₂FUME[®] dispensing equipment at the conclusion of fumigation, all residual gas in the equipment should be vented to atmospheric pressure. The cylinder valve should be closed and the remaining product within the supply line discharged through the dispensing equipment. Cylinders should not be disconnected before ensuring that the line is fully vented.

4. Liquid Expansion

Liquefied gases expand rapidly when they are warmed. Because of this characteristic, liquid ECO₂FUME[®] should never be trapped between the shutoff valve on the cylinder and the shutoff valve on the dispensing equipment, without adequate safety relief devices in place. Only approved application equipment should be used because of this hazard.

III. PRECAUTIONARY STATEMENTS

ECO₂FUME[®] is a restricted use product for the retail sale and use only by certified applicators and people under their direct supervision.

A. HAZARDS TO HUMANS AND DOMESTIC ANIMALS

Keep Out of Reach of Children

DANGER-POISON

May be fatal if inhaled. The liquid may cause burns. Avoid contact with skin and eyes and avoid breathing vapor. Use in well ventilated areas. Keep animals, children and unauthorized persons away from area under treatment until area is shown to be free from phosphine gas, as indicated by a gas-measuring device. Where the concentration of phosphine is unknown, a self-contained breathing apparatus (SCBA) with full facepiece and operated in pressure-demand mode must be used.

Do not get in eyes, in nose, on skin or on clothing. Do not eat, drink or smoke while handling ECO₂FUME[®]. Phosphine gas may deaden the sense of smell. Do not depend solely on the odor to detect ECO₂FUME[®]. Observe proper application, aeration and reentry procedures specified in the Application Manual (IX. APPLICATOR AND WORKER EXPOSURE) to prevent overexposure.

EXPOSURE TO CONCENTRATIONS ABOVE PERMISSIBLE LEVELS MAY CAUSE POISONING.

B. NOTE TO PHYSICIAN - THIS IS PHOSPHINE; IT IS NOT PHOSGENE

ECO₂FUME[®] is a gaseous mixture of phosphine and carbon dioxide. Mild exposure by inhalation causes malaise (indefinite feeling of sickness), ringing of ears, fatigue, nausea and pressure in chest which are relieved by removal to fresh air. Moderate poisoning causes weakness, vomiting, epigastric pain (pain just above the stomach), chest pain, diarrhea and dyspnea (difficulty in breathing). Symptoms of severe poisoning may occur within a few hours or up to several days, resulting in pulmonary edema (fluid in lungs) and may lead to dizziness, cyanosis (blue or purple skin color), unconsciousness and death.

In sufficient quantity, phosphine affects the liver, kidneys, lungs, nervous system, and circulatory system. Inhalation can cause lung edema (fluid in lungs) and hyperemia (excess of blood in a body part), small perivascular brain hemorrhages and brain edema (fluid in brain). Phosphine poisoning may result in (1) pulmonary edema, (2) liver elevated serum GOT, LDH and alkaline phosphatase, reduced prothrombin, hemorrhage and jaundice (yellow skin color) and (3) kidney

hematuria (blood in urine) and anuria (abnormal or lack of urination). Pathology is characteristic of hypoxia (oxygen deficiency in body tissue). Frequent exposure over a period of days or weeks may cause poisoning. Treatment is symptomatic.

The following measures are suggested for use by the physician in accordance with the physician's own judgment:

1. Exposure of skin to rapidly evaporating liquid may cause cryogenic "burn." Treat the "burn" in a similar manner as a thermal burn.
2. In case of freezing or cryogenic "burns" to eyes by rapidly evaporating liquid, RINSE EYES WITH COOL WATER. Do not rinse eyes with hot or even tepid water.
3. In its milder to moderate forms (symptoms of poisoning may take up to 24 hours to make their appearance), the following is suggested:
 - a. Complete rest 1-2 days during which the patient must be kept quiet and warm.
 - b. If the patient suffers from vomiting or increased blood sugar, appropriate solutions should be administered. Treatment with oxygen is recommended, as is the administration of cardiac and circulatory stimulants.
4. In cases of severe poisoning (intensive care unit recommended):
 - a. Where pulmonary edema is observed, steroid therapy should be considered and close medical supervision is recommended. Blood transfusions may be necessary.
 - b. In case of manifest pulmonary edema, venesection should be performed under vein pressure control. Heart glycosides (I.V.) can be used in case of hemoconcentration. Venesection may result in shock. In the case of progressive edema of the lungs, immediately intubate and remove edema fluid and administer oxygen over-pressure respiration, as well as any measures required for shock treatment. In case of kidney failure, extracorporeal hemodialysis is necessary. There is no specific antidote known for this poisoning.

C. ENVIRONMENTAL HAZARDS

Phosphine gas is highly toxic to fish and wildlife. Exposure to non-target organisms should be avoided.

D. PHYSICAL AND CHEMICAL HAZARDS

Phosphine may ignite spontaneously at levels above its lower flammability limit of 1.8% v/v (18,000 ppm). It is important not to exceed this concentration. Ignition of high concentration of phosphine can produce a very energetic reaction. Explosions can occur under these conditions and may cause severe personal injury. For this reason, the ratio of phosphine and carbon dioxide in ECO₂FUME[®] was specifically chosen to ensure the mixture is nonflammable in all proportions with air.

Contents under pressure. Do not use or store near heat or open flame. Do not puncture or incinerate container. Exposure to temperatures above 130°F may cause bursting. Do not drop the container.

Never open cylinder in a confined space without an SCBA with full facepiece operated in pressure-demand mode. Never enter a space under fumigation with ECO₂FUME[®] without first checking the gas concentration levels and wearing the appropriate breathing apparatus. Phosphine gas has a low solubility in water and oils and is stable at normal fumigation temperatures. However, it may react with certain metals and cause corrosion, especially at higher temperatures and relative humidities. Metals such as copper, brass and other copper alloys, and precious metals such as gold and silver are susceptible to corrosion. Thus, small electric motors, smoke detectors, brass sprinkler heads, batteries and battery

chargers, fork lifts, temperature monitoring systems, switching gears, communication devices, computers, calculators and other electronic or electrical equipment should be protected or removed before fumigation. In most cases all electronic equipment must be removed. Phosphine gas will also react with certain metallic salts and therefore, sensitive items such as photographic film, some inorganic pigments, etc., should not be exposed.

IV. DIRECTIONS FOR USE

A. GENERAL

1. It is a violation of federal law to use this product in a manner inconsistent with its labeling.
ECO₂FUME[®] is a Restricted Use Pesticide due to the acute inhalation toxicity of phosphine, PH₃ gas. For retail sale to dealers and certified applicators only. For use by certified applicators or persons under their direct supervision, and only for those uses covered by the Certified Applicator's certification. Refer to the directions in this applicator manual for requirements of the physical presence of a Certified Applicator. Before using, read and follow the label precautions and directions on the label and in the ECO₂FUME[®] manual. Additional copies of this manual are available from CYTEC Canada Inc., Niagara Falls, Ontario, Canada, Customer Service Department, Phone No. (905)374-5899 or (905) 374-5901; Fax No. (905) 374-5888.
2. Requirements for Certified Applicator to be present and responsible for all workers:
 - a. A Certified Applicator must be physically present, responsible for, and maintain visual and/or voice contact with all fumigation workers during the application of the fumigant. Once the application is complete and the structure has been made secure the certified applicator does not need to be physically present at the site.
 - b. A Certified Applicator must be physically present, responsible for and maintain visual and/or voice contact with all fumigation workers during the initial opening of the fumigation structure for aeration. Once the aeration process is secured and monitoring has established that aeration can be completed safely the certified applicator does not need to be physically present and trained person(s) can complete the process and remove the placards.
 - c. Persons with documented training in the handling of Phosphine products must be responsible for receiving, aerating and removal of placards from vehicles, transport containers and trailers which have been fumigated in-transit.
3. Requirements for Reentry Following Fumigation:
At least two persons trained in confined space entry must be present during reentry into a fumigated or partially aerated site. One of these two persons should also be a Certified Applicator. One of the persons should serve as an observer while the other enters the facility. The second person should not enter the facility and should seek help in the event of an emergency.
4. Preparation and Notification Requirements for Fumigation Sites:
Prior to applying this product, the storage structure must be inspected to determine if it can be made sufficiently gas tight. The storage structure should be sealed so as to maintain a suitable gas concentration over the time period required for control of insects. Personal exposure monitoring should be conducted by use of personal electronic monitors or low level detection tubes, as appropriate. Notify appropriate owners, employees, and/or operators at the facility where the fumigation will occur, and provide relevant safety, health and environmental information to local fire and rescue officials annually for use in the event of an emergency. For additional information consult the manufacturer manuals and training information about safe and effective use of ECO₂FUME[®].
5. Protect or remove copper, silver, gold and their alloys from corrosive exposure to phosphine.

B. EFFICACY

Complete control of listed pests may not always be achieved. Factors contributing to less than 100% control include gas leakage, poor gas distribution, unfavorable exposure conditions, etc. Improperly sealed areas may allow pests (especially rodents and other invertebrates) to escape to non-fumigated areas. In addition, some insects are less susceptible to phosphine than others. To maximize control, extreme care must be observed in sealing, higher dosages must be used, exposure periods must be lengthened, proper application procedures must be followed, and temperature and humidity must be favorable.

C. USE PATTERN

1. PESTS

ECO₂FUME[®] Fumigant Gas will control the following pests:

a. Insects, including:

Almond Moth	Angoumois Grain Moth
Bean Weevil	Cadelle
Carpet Beetle	Cereal Leaf Beetle
Cigarette Beetle	Confused Flour Beetle
Dermestid Beetle	Dried Fruit Beetle
Dried Fruit Moth	European Grain Moth
Flat Grain Beetle	Fruit Flies
Granary Weevil	Greater Wax Moth
Hairy Fungus Beetle	Hessian Fly
Khapra Beetle	Indian Meal Moth
Lesser Grain Borer	Maize Weevil
Mediterranean Flour Moth	Pea Weevil
Pink Bollworm	Raisin Moth
Red Flour Beetle	Rice Weevil
Rusty Grain Beetle	Saw-toothed Grain Beetle
Spider Beetles	Tobacco Moth
Warehouse Beetle	Yellow Meal Worm
Bees	

b. Rodents and other vertebrate pests

c. Wood pests (specifically the pine wood nematode and other wood-infesting nematodes and beetles)

2. COMMODITIES

The following commodities can be fumigated with ECO₂FUME[®]:

a. Raw Agricultural Commodities

Alfalfa	Almonds	Avocado
Banana (includes	Barley	Brazil Nuts

Plantains)	Cabbage, Chinese	Cashews
Citrus Citron	Cocoa Beans	Coffee Beans
Corn	Cottonseed	Dates
Dill	Eggplant	Endive
Filberts	Flower Seed	Grapefruit
Grass Seed	Kumquats	Legume Vegetables (succ. or dried)
Lemon	Lettuce	Lime
Mango	Millet	Oats
Okra	Orange	Papaya
Pecans	Peanuts	Pepper
Persimmon	Pimento	Pistachio Nuts
Popcorn	Potato, Sweet	Rice
Rye	Safflower Seed	Salsify Tops
Sesame Seed	Sorghum	Soybeans
Sunflower Seed	Tangelo	Tangerine
Tomato	Triticale	Vegetable Seeds
Walnuts	Wheat	

b. Processed Foods

Processed foods that may be fumigated with ECO₂FUME[®].

Processed candy and sugar

Cereal flours and bakery mixes

Cereal foods (including cookies, crackers, macaroni, noodles, pasta, pretzels, snack foods and spaghetti)

Processed cereals (including milled fractions and packaged cereals)

Cheese and cheese by-products

Chocolate and chocolate products (such as assorted chocolate, chocolate liquor, cocoa, cocoa powder, dark chocolate coating and milk chocolate)

Processed coffee

Corn grits

Cured, dried and processed meat products and dried fish

Dates

Dried eggs and egg yolk solids

Dried milk, dried powdered milk, nondairy creamers, and nonfat dried milk

Dried or dehydrated fruits (such as citrus, apples, dates, figs, peaches, pears, prunes, raisins and sultanas)

Dried and dehydrated vegetables (such as beans, carrots, lentils, peas, potato flour, potato products and spinach)

Figs

Malt

Peanuts

Processed herbs, spices, seasonings and condiments

Processed nuts (almonds, apricot kernels, Brazil nuts, cashews, filberts, peanuts, pecans, pistachio nuts, walnuts and other processed nuts)

Processed oats (including oatmeal)

Rice (brewers rice grits, enriched and polished, wild rice)

Soybean flour and milled fractions

Processed tea

Yeast (including primary yeast)
 Wild rice
 Other processed foods

c. Animal Feed and Feed Ingredients

d. Nonfood Commodities Including Tobacco

Nonfood items that may be fumigated with ECO₂FUME[®]:

Animal hide
 Processed or unprocessed cotton, wool and other natural fibers or cloth, including clothing
 Clothing, feathers, furs, human hair, rubberized hair, vulcanized hair, mohair
 Leather products
 Tobacco
 Wood, cut trees, wood chips and wood and bamboo products
 Tires (for mosquito control)
 Paper and paper products
 Non-food flour
 Dunnage
 Non-food starch
 Fresh or dried plants and flowers
 Bulbs, tubers, corms and rhizomes
 Seeds (grass seed, ornamental herbaceous plant seed, and vegetable seed)
 Straw or hay
 Psyllium seed and psyllium seed husks**
 Other nonfood commodities

**Psyllium seed and Psyllium seed husks destined for shipment to pharmaceutical manufacturers may be fumigated. Such dedicated lots may be fumigated in transport vehicles (truck trailers, railcars and containers) prior to shipment. In addition, psyllium seed and husks may be fumigated at other locations only under direct instructions from the pharmaceutical company.

D. DOSAGE GUIDE

RECOMMENDED PHOSPHINE DOSAGES FOR ECO₂FUME^{®1,2,3}

Temperature	PH ₃ Concentration Maintained/1000 ft ³ of Area	Rate of ECO ₂ FUME [®] /1,000 cu. Ft.	Minimum Duration
Below 32°F (0° C)	Do not fumigate	Do not fumigate	Do not fumigate
32-39° F (0-4° C)	200-1,000 ppm	0.88 – 4.41 lb	6 days
40-53° F (5-12° C)	200-1,000 ppm	0.88 – 4.41 lb	4 days ⁴
54-59° F (12-15° C)	200-1,000 ppm	0.88 – 4.41 lb	3 days
60-79° F (16-25° C)	200-1,000 ppm	0.88 – 4.41 lb	2 days
80° F & Above (=26° C)	200-1,000 ppm	0.88 – 4.41 lb	36 hours
80° F & Above (=26° C)	500-1,000 ppm	2.20 – 4.41 lb	24 hours

¹ For other calculations, refer to Section IV.H.2.f

² Recommendations for spot treatment applications are provided in Section IV.H.8.

³ When fumigating wood or wood products, the fumigation rate may need to be adjusted depending upon the moisture content of the wood or wood product. For best results, fumigate with a dose of 750-1000 ppm phosphine for 10 days. Higher concentrations are recommended to counter the solubility of phosphine in water or moisture present in the wood or wood product. If fumigating for quarantine purposes, check with the receiving country concerning accepted fumigation methods for the specific product being fumigated.

⁴ ECO₂FUME Fumigant Gas can be used on cocoa beans to control all stages of those moth species (including Indian Meal Moth) that commonly infest cocoa beans in a 24-hour exposure time with 500-1000 ppm phosphine at a temperature of 40°F or higher.

Rodents and other vertebrate pests in storages may be controlled with short-term fumigations within 1 to 4 hours after achieving distribution of phosphine throughout the structure.

Restriction: After introduction and stabilization, the maximum concentration of phosphine maintained during fumigation should not exceed 1,000 ppm.

E. EXPOSURE GUIDELINES

The above table may be used as a guide in determining the minimum length of the exposure at the indicated temperatures. These are the temperatures found within the immediate surroundings of the target pest (cold walls, center of grain mass, etc.). For example, this means that a minimum of 200 parts per million of phosphine from ECO₂FUME[®] is necessary for 2 days at 60-79° F at the location of the pest insect. This does not mean the ambient temperature the fumigator is experiencing but the localized concentration and temperature next to the pest insects.

Some insect species and life stages are harder to kill than others. It is important that target pests are known and understood. For example, overwintering dormant larva may be more difficult to kill than an active larva of the same species. Use of the maximum duration is recommended when possible. Insects, in general, are more difficult to control at lower temperatures because of factors such as slower respiration and slower diffusion of the fumigant into the space and commodity.

Short treatment times are effective at high temperatures (80°F and above). At these higher temperatures a treatment time of one day is sufficient to kill most storage pests, however, two days may be needed to destroy 100% of the eggs of some storage pests (e.g., *Amyelois transitella*, *tribolium* spp., and *Trogoderma variabile*). Knowing the pest and life stage to control is critical to determining the dose and treatment time needed.

Certain stored product insects are more tolerant and harder to kill. Here is a partial list of those insect species: Rice weevil, Granary weevil, Maize weevil (*Sitophilus* spp.), Lesser grain borer (*Rhyzopertha dominica*), Warehouse beetle (*Trogoderma* spp.), Carpet beetle (*Attagenus/Anthrenus* spp.), and Cigarette beetle (*Lasioderma serricorne*).

Consequently, exposure periods recommended in the table are minimum periods and may not be adequate to control all stages of stored product pests under all conditions. This is particularly true at lower temperatures (below 60 degrees F) due to the lower activity and respiration levels of insects.

Fumigators also should be aware that different types of packaging will influence the penetration rate of the gas. Selection of appropriate exposure should be considered accordingly.

The key to a successful fumigation remains with correct dosage, adequate exposure periods, proper application procedures and well-sealed enclosures.

F. SEALING

Good sealing is necessary for an effective fumigation. Turn off all ventilation, supply air, air conditioning, and any other air moving systems that could negatively effect the fumigation. Thoroughly inspect the fumigation chamber/area and seal all cracks, holes and openings. These areas could include, but are not limited to: windows, doors, vents, chimneys and structural flaws. Sealing techniques can vary, but most often include polyethylene sheeting, adhesive tapes and adhesive sprays. Expandable foam or caulking material can work well on structural flaws. Proper sealing will ensure sufficient gas levels within the fumigated area and will decrease the chance of unwanted exposure outside of the fumigated area.

As with all fumigations, perimeter monitoring for leaks and potential exposures is required. If phosphine above 0.3 ppm is found in an area where exposure to workers or bystanders may occur, the addition of fumigant must be stopped. Using the proper protective equipment, the applicator must attempt to seal the leak from the exterior of the structure. Failing this, the applicator must follow all proper procedures for confined space entry including wearing SCBA with full facepiece and operated in pressure-demand mode, and seal the leak from the interior. At times the applicator may find that all the calculated amount of fumigant has been added, however the target concentration has not been reached. In this case, the fumigator must first check the calculations. It is possible the phosphine concentration is localized and has not had enough time to disperse evenly. Continue to monitor the inside concentration while checking for leaks as above. All structures will leak to some degree. Large leaks must be repaired to minimize loss of fumigant to the environment and reduce risk of potential exposure to personnel. Fence-line concentrations must never be allowed to exceed the TLV of 0.3 ppm.

Phosphine gas is highly mobile and given enough time may penetrate seemingly gas-tight materials such as concrete and cinder block. Therefore, adjacent, enclosed areas likely to be occupied must be examined to ensure that significant leakage has not occurred. Sealing of the fumigated site and/or airflow in the occupied areas must be sufficient to bring down the phosphine concentration to a safe level of 0.3 ppm or below.

G. FUMIGATION MANAGEMENT PLANS

The certified applicator is responsible for working with the owners and/or responsible employees of the site to be fumigated to develop a Fumigation Management Plan (FMP). The FMP is intended to ensure a safe and effective fumigation. The FMP must address characterization of the site, and include appropriate monitoring and notification requirements, consistent with, but not limited to, the following:

1. Inspect the structure and/or area to determine its suitability for fumigation.
2. When sealing is required, consult previous records for any changes to the structure, seal leaks, and monitor any occupied adjacent buildings to ensure safety.
3. Prior to each fumigation, review any existing FMP, MSDS, Applicators Manual and other relevant safety procedures with company officials and appropriate employees.
4. Consult company officials in the development of procedures and appropriate safety measures for nearby workers that will be in and around the area during application and aeration.
5. Consult with company officials to develop an appropriate monitoring plan that will confirm that nearby workers and bystanders are not exposed to levels above the allowed limits during application, fumigation and aeration. This plan must also demonstrate that nearby residents will not be exposed to concentrations above the allowable limits.
6. Consult with company officials to develop procedures for local authorities to notify nearby residents in the event of an emergency.

7. Confirm the placement of placards to secure entrance into any area under fumigation.
8. Confirm the required safety equipment is in place and the necessary manpower is available to complete a safe effective fumigation.
9. Written notification must be provided to the receiver of a vehicle that is fumigated in transit.

These factors must be considered in putting a FMP together. It is important to note that some plans will be more comprehensive than others. All plans should reflect the experience and expertise of the applicator and circumstances at and around the structure and/or area.

In addition to the plan, the applicator must read the entire label and application manual and follow their directions carefully. If the applicator has any questions about the development of a FMP contact Cytec Industries Inc. for further assistance.

The FMP and related documentation, including monitoring records, must be maintained for a minimum of 2 years.

1. Guidance for Preparation of a Fumigation Management Plan

Purpose

A Fumigation Management Plan (FMP) is an organized, written description of the required steps involved to help ensure a safe, legal, and effective fumigation. It will also assist you and others in complying with pesticide product label requirements. The guidance that follows is designed to help assist you in addressing all the necessary factors involved in preparing for and fumigating a structure and/or area.

This guidance is intended to help you organize any fumigation that you might perform **PRIOR TO ACTUAL TREATMENT**. It is meant to be somewhat prescriptive, yet flexible enough to allow the experience and expertise of the fumigator to make changes based on circumstances that may exist in the field. By following a step-by-step procedure, yet allowing for flexibility, a safe and effective fumigation can be performed.

Before any fumigation begins, carefully read and review the label and the Applicator's Manual. This information must also be given to the appropriate company officials (supervisors, foreman, safety officer, etc.) in charge of the structure and/or area. Preparation is the key to any successful fumigation. If the type of fumigation that you are to perform is not listed in this Guidance Document you will want to construct a similar set of procedures. Finally, before any fumigation begins you must be familiar with and comply with all applicable state and local laws. The success of the fumigation is not only dependent on your ability to do your job but also upon carefully following all rules, regulations, and procedures required by governmental agencies.

2. A Checklist Guide for a Fumigation Management Plan

This checklist is provided to help you take into account factors that must be addressed prior to performing all fumigation's. It emphasizes safety steps to protect people and property. The checklist is general in nature and cannot be expected to apply to all types of fumigation situations. It is to be used as a guide to prepare the required plan. Each item must be considered, however, it is understood that each fumigation is different and not all items will be necessary for each fumigation structure and/or area.

A. PRELIMINARY PLANNING AND PREPARATION

1. Determine the purpose of the fumigation.
 - a. Elimination of pest infestation

- b. Plant pest quarantine.
2. Determine the type of fumigation, for example:
 - a. Space; tarp, mill, warehouse, food plant
 - b. Vehicle; railcar, truck, van, container
 - c. Commodity; raw agricultural or processed foods
 - d. Grain; vertical silo, farm storage, flat storage
 - e. Vessels or ships (not for use on barges). In addition to the Applicator's Manual, read the US Coast Guard Regulations 46CFR 147A.
 3. Fully acquaint yourself with the structure and/or area and commodity to be fumigated, including:
 - a. The general structure layout, construction (materials, design, age, maintenance, of the structure, fire or combustibility hazards, connecting structures and escape routes, above and below ground, and other unique hazards or structure characteristics. Prepare, with the owner/operator/person in charge. Draw or have a drawing or sketch of structure to be fumigated, delineating features, hazards, and other structural issues.
 - b. The number and identification of persons who routinely enter the area to be fumigated (i.e., Employees, visitors, customers, etc.).
 - c. The specific commodity to be fumigated, its mode of storage, and its condition.
 - d. The previous treatment history of the commodity, if available.
 - e. Accessibility of utility service connections.
 - f. Nearest telephone or other means of communication, and mark the location of these items on the drawing/sketch.
 - g. Emergency shut-off stations for electricity water and gas. Mark the location of these items on the drawing/sketch.
 - h. Current emergency telephone numbers of local Health, Fire, Police, Hospital and Physician responders.
 - i. Name and phone number (both day and night) of appropriate company officials.
 - j. Check, mark and prepare the points of fumigation application.
 - k. Review labeling and Applicator's Manual.
 - l. Exposure time considerations.
 - 1. Fumigant to be used.
 - 2. Minimum fumigation period, as defined and described by the label use directions.
 - 3. Down time required to be available.
 - 4. Aeration requirements.
 - 5. Measure and recorded commodity temperature.
 - m. Determination of dosage.
 - 1. Cubic footage or other appropriate space/location calculations.
 - 2. Structure sealing capability and methods.
 - 3. Label recommendations.
 - 4. Temperature and wind.
 - 5. Commodity/space volume.
 - 6. Past history of fumigation of structure
 - 7. Exposure time.
 - 8. Commodity Type
 - 9. Pest and life stage

B. PERSONNEL

1. Confirm in writing that all personnel in and around the area to be fumigated have been notified prior to application of the fumigant. Consider using a checklist that each employee initials indicating they have been notified.
2. Instruct all fumigation personnel about the hazards that may be encountered; and about the selection of personal protection devices, including detection equipment.
3. Confirm that all personnel are aware of and know how to proceed in case of an emergency situation.
4. Instruct all personnel on how to report any accident and/or incidents related to fumigant exposure. Provide a telephone number for emergency response reporting.

5. Instruct all personnel to report to proper authorities any theft of fumigant and/or equipment related to fumigation.
6. Establish a meeting area for all personnel in case of emergency.
7. Confirm that all applicators have been trained in the use of ECO₂FUME[®] Fumigant Gas and are in good standing including the required refresher training.

C. MONITORING

1. Perimeter Safety
 - a. Monitoring of phosphine concentrations must be conducted in areas to prevent excessive exposure and to determine where exposure may occur. Document where monitoring will occur.
 - b. Keep a log or manual of monitoring records for each fumigation site. This log must at a minimum contain the timing, number of readings taken and level of concentrations found in each location.
 - c. When monitoring for leaks, document there is no phosphine present above the safe levels. Subsequent leak monitoring is not routinely required. However spot checks must be made, especially if conditions significantly change.
 - d. Monitoring must be conducted during aeration and corrective action taken if gas levels exceed the allowed levels in an area where bystanders and/or nearby residents may be exposed.
2. Efficacy
 - a. Gas readings should be taken from within the fumigated structure to ensure proper gas concentrations. This can be safely achieved outside the structure through the use of sample lines.
 - b. All phosphine readings should be documented.

D. NOTIFICATION

1. Confirm that all appropriate local authorities (fire departments, police departments, etc.) have been notified as per label instructions, local ordinances if applicable, or instructions of the client.
2. Prepare written procedure (“Emergency Response Plan”) which contains explicit instructions, names, and telephone numbers so as to be able to notify local authorities if phosphine levels are exceeded in an area that could be dangerous to bystanders and/or domestic animals.
3. Confirm that the receivers of vehicles and containers under in-transit fumigation have been notified and that trained workers will be available on site (IV. H. 6. c. under DIRECTIONS FOR USE).

E. SEALING PROCEDURES

1. Sealing must be adequate to control pests. Care should be taken to ensure that sealing materials will remain intact until the fumigation is complete.
2. If the structure and/or area has been fumigated before, review the previous FMP for previous sealing information.
3. Make sure that construction/remodeling has not changed the building in a manner that will affect the fumigation.
4. Warning placards must be placed on every possible entrance to the fumigation site.

F. APPLICATION PROCEDURES & FUMIGATION PERIOD

1. Plan carefully and apply all fumigants in accordance with the label requirements.
2. When entering into the area under fumigation always work with two or more people under the direct supervision of a certified applicator wearing appropriate respirators.
3. Apply fumigant from outside the fumigation space.
4. Provide watchmen when a fumigation site cannot otherwise be made secure from entry by unauthorized persons.
5. When entering structures always follow OSHA rules for confined spaces.
6. Document that the receiver of vehicles fumigated in transit has been notified and is trained to receive commodity under fumigation.

G. POST-APPLICATION OPERATIONS

1. Provide watchmen when you cannot secure the fumigation site from entry by unauthorized persons during the aeration process.
2. Ventilate and aerate in accordance with structural limitations.
3. Turn on ventilating or aerating fans where appropriate.
4. Use a suitable gas detector before reentry to determine fumigant concentration.
5. Keep written records of monitoring to document completion of aeration.
6. Consider temperature when aerating.
7. Ensure aeration is complete before moving vehicle into public roads.
8. Remove warning placards when aeration is complete.
9. Inform business/client that employees/other persons may return to work or otherwise be allowed to reenter the aerated structure.

H. APPLICATION PROCEDURES

1. General Statement

A Fumigation Management Plan (FMP) (see Section IV. G above) must be prepared for all structures and containers before fumigation is started in order to prevent human and animal exposure to phosphine and to help assure adequate control of insect pests.

The following instructions are intended to provide general guidelines for typical fumigation. There are a number of critical factors involved in the design of dispensing equipment. As such, dispensing equipment must meet both high-pressure standards and chemical compatibility requirements. Improper or inappropriate use of dispensing equipment may result in severe injury or death. Application inconsistent with the labeling and Application Manual is a violation of Federal law. Buyer assumes all risk should the product be used contrary to label or Application Manual instructions.

2. Equipment Specification and Use

a. General

The equipment used to dispense ECO₂FUME[®] provides a means of containing the gas during the fumigation and controlling the release of the product into the desired space. While some dispensing equipment has been developed and used to date, they cannot be expected to cover all possible fumigation scenarios. The development of suitable dispensing equipment is an ongoing process, based on the needs of the users and available technology.

The design of dispensing equipment must account for a number of technical issues, including pressure rating, material compatibility, temperature limitations and operator safety. For this reason, only appropriate equipment should be used in the dispensing of ECO₂FUME[®]. Only persons trained in the proper use of ECO₂FUME[®] and the dispensing equipment shall be permitted to use ECO₂FUME[®] for fumigation.

The instruction materials provided with the dispensing equipment should be consulted for their proper use and maintenance.

b. Unapproved Dispensing Methods

It has been common practice, with other cylinderized fumigants, to place the cylinder in the space to be fumigated and the cylinder outlet valve opened to allow the fumigant to release. This is not an approved dispensing method and should not be used with ECO₂FUME[®].

c. Approved Dispensing Methods

The approved dispensing methods for ECO₂FUME[®] include placing the cylinder outside the fumigation area. Pressure reducing regulators should be used for slow release, and selected piping components should be used for quick release. The slow release of ECO₂FUME[®] is generally used for fumigating bulk storage facilities such as silos or bins, or for small fumigation chambers or spaces and for fumigation of stacked materials under tarpaulins. The quick release method is used for space fumigation, or where the commodity to be treated is warehoused. The selection of the dispensing method will depend on the size of the fumigation, the time required and facility limitations.

d. Regulated Dispensing Equipment

Regulated dispensing equipment has been developed for use with ECO₂FUME[®]. The regulated dispensers are designed to reduce the high cylinder pressure to a low pressure (less than 100 psig exit the pressure regulator) and provide the heat necessary to vaporize the fumigant. This pressure is further reduced to near ambient exit the flow control valve. Once reduced to this lower pressure, the fumigant may be distributed to the desired dispensing points using inexpensive and easy to use materials, such as plastic tubing. Flow indicators are used with regulated dispensers to measure and set the dispensing rate.

ECO₂FUME[®] regulator assemblies, equipped with basic features, are available through authorized ECO₂FUME[®] distributors. Multiple regulators may be used together to achieve higher fumigant flows than available through a single regulator and custom equipment can be developed for specific types of applications.

e. Quick Release Dispensing Equipment

For cases where the fumigation space is very large, such as a mill, warehouse, large tarpaulin or large fumigation chamber, and the use of a number of cylinders is anticipated, a quick means of dispensing ECO₂FUME[®] is available. Specially selected components can be used to direct the cylinder discharge into the fumigation space, without the need to enter the space itself during the fumigation. A single cylinder can be discharged using this method in as little as 20 minutes. Unlike the regulated dispensing methods, the dispensing rate is not adjustable and generally, entire cylinders are emptied using this process. If partial cylinder contents are needed, the ECO₂FUME[®] cylinder can be placed on a weight scale and the amount of fumigant released can be measured. The quick release method must not be used for fumigation of small sized fumigation of stacked materials under tarpaulins. The use of regulated dispensing equipment or flow restricting nozzles to control the rate of ECO₂FUME[®] dispensing is recommended for small tarpaulin fumigations (see IV.G.5.3 Applications to Tarpaulin Fumigations).

f. Calculating the Amount of ECO₂FUME[®] Required

The amount of ECO₂FUME[®] required to perform a fumigation will depend on (i) type of space to be fumigated and its sealability, (ii) type of commodity, (iii) type of insect pest, its life stage and resistance level, (iv) temperature at the infestation site, (v) duration of fumigation, (vi) use of any re-circulation devices and (vii) whether or not it is stationary or in-transit fumigation.. An initial dose of ECO₂FUME[®] is used to establish a pesticidal atmosphere in the fumigation space, and through active monitoring of the phosphine concentrations, additional ECO₂FUME[®] added as required to maintain the target concentration for the prescribed time period.

The initial dose of fumigant is based on the total volume of the space to be fumigated and the target phosphine concentration desired. When dispensing ECO₂FUME[®] it is sometimes easier to speak in terms of the amount of phosphine that is required rather than the amount of ECO₂FUME[®].

One gram of phosphine (PH₃) will produce a concentration of 25 parts per million (ppm) in a volume of 1000 cubic feet (ft³). This is the fundamental conversion used when calculating the amount of ECO₂FUME[®] needed to dose a space.

To calculate the total amount of phosphine or ECO₂FUME[®] required to dose a space:

$$1 \text{ gram PH}_3 = 25 \text{ ppm PH}_3/1000 \text{ ft}^3$$
$$1 \text{ pound ECO}_2\text{FUME}^{\text{®}} = 9.07 \text{ grams PH}_3$$

$$\text{grams of PH}_3 = (\text{Target Concentration} \times \text{Volume}) / 25,000$$

or

$$\text{pounds of ECO}_2\text{FUME}^{\text{®}} = (\text{Target Concentration} \times \text{Volume}) / 226,800$$

“Target” is the desired phosphine concentration in parts per million (ppm).

“Volume” is the empty volume of the space to be fumigated in cubic feet (ft³).

To calculate the amount of phosphine or ECO₂FUME[®] to be added to a space to reestablish the Target concentration:

$$\text{grams of PH}_3 = (\text{Target Concentration} - \text{Actual}) \times \text{Volume} / 25,000$$

or

$$\text{pounds of ECO}_2\text{FUME}^{\text{®}} = (\text{Target Concentration} - \text{Actual}) \times \text{Volume} / 226,800$$

“Target” is the desired phosphine concentration in parts per million (ppm).

“Volume” is the empty volume of the space to be fumigated in cubic feet (ft³).

“Actual” is the measured phosphine concentration in parts per million (ppm).

As a general rule, 200 ppm of PH₃ in ECO₂FUME[®] will release 7,700 ppm of carbon dioxide in the fumigation space.

When adding ECO₂FUME[®] to a space, the phosphine concentration should be actively monitored. This can be accomplished from outside the space by use of plastic sample tubing run through an opening and securely attached to a point inside the space. If the desired concentration is achieved before the calculated amount of ECO₂FUME[®] has been added, the addition of ECO₂FUME[®] should be stopped and the calculations should be checked. It is possible that a localized higher concentration has been detected and the ECO₂FUME[®] requires more time to evenly disperse.

When a partial cylinder of ECO₂FUME[®] is required, the cylinder can be placed on a scale and the amount of fumigant released can be measured. The scale can also be used to check how much ECO₂FUME[®] is left in the cylinder by comparing this weight to the tare weight. The tare weight is stamped near the top of the cylinder and distinguished with the letters "TW". Subtract the tare weight from the measured weight and the difference is the amount of product left in the cylinder.

g. Troubleshooting

This section is provided to assist in addressing problems that may be encountered while using ECO₂FUME[®] cylinders. In the event of potential leaking structures, refer to Section F. SEALING. When troubleshooting leaking

cylinders, SCBA is required when levels of phosphine are unknown, or known to exceed the short-term exposure limit (STEL; 1 ppm for 15 minutes for phosphine). Troubleshooting assistance for a particular piece of dispensing equipment is addressed in the respective equipment manual. Questions for problems other than those listed below should be directed to the authorized ECO₂FUME[®] distributor.

- (1) Condensation is forming on the outside of the cylinder.
This is normal. As the fumigant is removed from the cylinder, the liquefied gas mixture boils to maintain the pressure in the cylinder gas space. This results in a chilling of the cylinder, and the condensing of moisture from the air.
- (2) Ice has formed on the bottom of the cylinder.
This is normal. When the liquid fumigant level in the cylinder falls below the dip tube, gas only can be withdrawn, and the liquid that remains in the cylinder must vaporize in order to be released. If the dispensing rate is high enough, the temperature that results from chilling can be below the freezing point for water. Instead of ambient moisture simply condensing, it freezes on the cylinder surface.
- (3) There is a leak at the cylinder valve. REFER TO SECTION XIV- SPILL AND LEAK PROCEDURES.
 - (a) There is a leak at the cylinder valve outlet.
 - (i) If the cylinder is attached to the dispensing equipment:
The connection to the valve outlet might be the problem. If tightening (but not over-tightening) the outlet connection does not solve the problem, close the cylinder valve and use the dispensing equipment to vent the remaining fumigant in the line. Disconnect the connection to the cylinder and inspect the fitting and valve outlet for damage. If the fitting is damaged, replace it. If the valve outlet is damaged, do not use the cylinder. Attach a tag to the cylinder conspicuously indicating “Bad Valve Outlet” and return it.
 - (ii) If the cylinder is not attached to the dispensing equipment:
Check to see if the cylinder valve is fully closed. If it is fully closed and the leak continues, the cylinder should be moved to a well-ventilated area, away from personnel. Refer to Spill and Leak Procedures.
 - (b) The leak is not at the cylinder valve outlet.
Assistance is required. Refer to Spill and Leak Procedures.
- (4) Gas is not dispensing.

Check to see if the cylinder is empty. First connect a 1000 psig pressure gauge to the cylinder outlet using a CGA 350 fitting. Open the cylinder valve and check the pressure gauge. If pressure is measured, the cylinder is not empty and a problem with the dispensing equipment is possible. Consult the dispensing equipment instructions for troubleshooting assistance. If no pressure is measured, weigh the cylinder (without the cap) and compare it to the cylinder tare (empty) weight. The tare weight is stamped near the top of the cylinder and distinguished with the letters “TW”. Subtract the tare weight from the measured weight. The difference is the amount of product in the cylinder. If there is a weight difference, then the cylinder has product and the outlet valve is faulty. Do not attempt to use the cylinder. Attach a tag to the cylinder indicating “bad valve” and return it to your distributor.

3. APPLICATION TO BULK COMMODITIES

a. Storage

ECO₂FUME[®] can be used to fumigate any type of storage used to hold listed bulk commodities. These include, but are not limited to bins, tanks, flat storage, and bunkers. The most important aspects of a successful fumigation, as with any fumigant, are the degree to which the space is sealed and the assurance that the minimum fumigant concentrations are maintained for the required time.

b. Develop and follow an appropriate Fumigation Management Plan (Refer to Section IV. G. Fumigation Management Plans).

c. Procedure for Fumigating Bulk Commodities

1. Calculate the empty volume space to be treated.
2. Determine the target phosphine concentration desired and the duration of the fumigation based on area fumigated (space volume), the insect pest(s) involved and the commodity temperature.
3. Calculate how much fumigant will be required and the means by which it will be dispensed.
4. Determine where the fumigant will be dispensed into the space, and plan for and install required equipment.
5. Gas monitoring should be performed from outside the fumigated structure. Polyethylene tubing is used for remote monitoring. This tubing can be run from each area of the fumigation to an outside location where gas samples can be taken safely. At least one monitoring line should be run in each fumigated structure. In the event of multi-floored structures or compartmentalized buildings, monitoring should be performed in all major areas of the fumigated structure. Fans can be used to help distribute gas into smaller areas and the outer reaches of these structures.
6. Isolate and seal all connections to other storage and spaces that are not intended for fumigation.
7. Seal all openings including cracks, windows, doors, vents, eaves, hatches, loading and unloading connections and ventilation fans. Seal all penetrations used for fumigant dispensing and monitoring. Use proper safety equipment and entry procedures if confined space entry is required.
8. Lock all entrances to the space.
9. Ensure that all personnel, animals, and damageable goods are clear of the space to be treated and post fumigation placards on all points of access and any unloading penetrations.
10. Verify that all required safety equipment is available and in good working order.
11. Notify all personnel in nearby buildings at the facility that fumigant release is about to commence.
12. Connect the ECO₂FUME[®] cylinders to the dispensing equipment.
13. Dispense the initial dose of fumigant.
14. Periodically monitor the phosphine concentrations within the space, using suitable gas detection equipment, to ensure that the minimum concentrations are being maintained. During and immediately after dispensing of ECO₂FUME[®] the fumigation area should be monitored hourly for phosphine concentrations until stabilized. If concentration is falling rapidly, the applicator should investigate the structure for possible leak points. Seal any leak points found. In a well-sealed structure, the phosphine concentration should stabilize quickly and monitoring frequency can be reduced to daily measurements. The sampling frequency should

be adjusted and additional ECO₂FUME[®] added as required to ensure the desired phosphine concentrations are maintained during the fumigation period.

15. Dispense additional fumigant as required to maintain the desired phosphine concentrations. When no further fumigant is required, close all cylinder valves. Depressurize the dispensing equipment and disconnect all ECO₂FUME[®] cylinders. Ensure that the valve discharge cap is securely installed and replace the cylinder cap.
16. Before leaving the fumigation site, re-check barricades and placards at all entrances/exits into the fumigation space and/or area under fumigation to prevent entry by unauthorized people and animals during fumigation.
17. When the fumigation is complete, unseal the space and aerate (see VIII. AERATION OF FUMIGATED COMMODITIES and IX. E. AERATION AND REENTRY). Use suitable gas detection equipment to check both the carbon dioxide and phosphine concentrations before allowing entry into the space. Use appropriate breathing apparatus and entry procedures to avoid undue worker exposure.

Additional Considerations:

1. Dispensing and monitoring lines should be installed with loading, unloading and other operations in mind. If frequent fumigations are expected, permanently mounted lines should be secured within the space. If temporary lines are to be used, they should be installed so they can easily be removed at the end of the fumigation.
2. The use of additional tarpaulins or plastic sheeting atop the commodity should be considered, if there is a substantial open space above the stored product. This will help minimize the loss of phosphine from the commodity and the total amount of fumigant required.
3. Recirculation of fumigant by specially installed small blowers is an excellent means of distributing ECO₂FUME[®] throughout the space being treated. The use of existing aeration blowers is not suggested since their capacity is often so high that it assists in the loss of the fumigant. Small commercial blowers can be used to recirculate the atmosphere within the space being treated. ECO₂FUME[®] should be dispensed into the discharge of recirculation blowers. The blowers should not be run continuously, but long enough to ensure good fumigant distribution and each time fumigant is added.
4. For large storage facilities, multiple dispensing points should be considered to assist in the distribution of the fumigant.

4. APPLICATION TO SPACE FUMIGATIONS

a. Spaces

ECO₂FUME[®] can be used to fumigate any type of space where listed commodities are stored or processed, except barges. These include, but are not limited to mills, warehouses, processing facilities, packaging plants and other structures. The most important aspects of a successful fumigation, as with any fumigant, are the degree to which the space is sealed and the assurance that the minimum fumigant concentrations are maintained for the required time.

- b. Develop and follow an appropriate Fumigation Management Plan (Refer to Section IV. G.).
- c. Procedure for Fumigating Spaces

1. Calculate the empty volume of the space to be treated.
2. Determine the target phosphine concentration desired and the duration of the fumigation. This should be based on the target pests and the temperature of the space.
3. Calculate how much fumigant will be required and the means by which it will be dispensed. Since space fumigations generally involve large volumes, fast dispensing methods are the best way to quickly achieve and maintain the desired phosphine concentrations.
4. Determine where the fumigant will be dispensed into the space, and plan for and install required components. Dispensing points should not be located in or attached to commodity packages. Securing the dispensing lines is important for fast dispensing, to minimize the chance of unwanted movement of the lines during discharge. Direct the discharge toward the center of the space being treated and away from equipment if possible.
5. Determine the number and location of circulating fans. Low speed fans should be placed on the floor and angled upwards. A means of turning the fans off from outside the treated space should be provided.
6. Determine where the fumigant concentrations will be measured (if used) and plan for and install required gas sampling lines.
7. Identify one access door and lock all others. Lock all ground level and other accessible windows if possible.
8. Except for the access door, seal all openings including cracks, windows, doors, vents, eaves, ventilation fans and points of material transfer. Seal all penetrations used for fumigation dispensing and monitoring. Isolate and seal all connections to other spaces that are not intended for fumigation.
9. Remove from the space, or protect sensitive equipment, material and food.
10. Ensure that all personnel, animals and damageable goods are clear of the space to be treated and post fumigation placards on and lock all points of access. The only exception to this is silo complexes connected by tunnels. Separate ventilation and monitoring must be in place to protect workers in adjacent areas.
11. Close, lock, seal and placard the access door.
12. Verify that all required safety equipment is available and in good working order.
13. Notify all personnel that fumigant release is about to commence.
14. Connect the ECO₂FUME[®] cylinders to the dispensing equipment.
15. Dispense the initial dose of fumigant.
16. Periodically monitor the phosphine concentrations within the space, using suitable gas detection equipment, to ensure that the minimum concentrations are being maintained.
17. Dispense additional fumigant as required to maintain the desired phosphine concentrations.
18. When no further fumigant is required close all cylinder valves. Depressurize the dispensing equipment and disconnect all ECO₂FUME[®] cylinders. Ensure that the valve discharge cap is securely installed and replace the cylinder cap.
19. Before leaving the fumigation site, recheck barricades and placards at all entries into the fumigation space and/or fumigated area to prevent entry by unauthorized personnel during fumigation
20. When the fumigation is complete, unseal the space and aerate (see VIII. AERATION OF FUMIGATED COMMODITIES and IX. E. AERATION AND REENTRY). Use suitable gas detection equipment to check both the carbon dioxide and phosphine concentrations before allowing entry into the space. Use appropriate breathing apparatus and entry procedures to avoid undue worker exposure.

21. Remove all dispensing and gas monitoring lines.
22. Workers should be aware that some residual gas may be entrapped within the fumigated commodity container (i.e. bagged product such as SUPERSACKS). Adequate monitoring and aeration must be performed to reduce any residual phosphine levels to below 0.3 ppm.

5. APPLICATION TO TARPAULIN FUMIGATIONS

a. General

ECO₂FUME[®] can be used to fumigate stacked materials by covering the material with a tarpaulin made from plastic sheeting. This allows the fumigant to be contained to the treated material only. The most important aspects of a successful fumigation, as with any fumigant, are the degree to which the space is sealed and the assurance that the minimum fumigant concentrations are maintained for the required time.

b. Develop and follow an appropriate Fumigation Management Plan (Refer to Section IV. G).

c. Procedure for Tarpaulin Fumigations

1. Since the volume of tarped materials can vary widely, it is important to make a good estimate of the volume enclosed by the tarp. Calculate the volume taken up by the material itself (palletized stacks for example) or any containers used to hold it. After tarping is complete, revise the volume estimate based on the additional empty space contained within the tarp.
2. Determine the target phosphine concentration desired and the duration of the fumigation. This should be based on the target pests and the temperature of the material being treated.
3. Calculate how much fumigant will be required, based on the volume calculation, and the means by which it will be dispensed. A means of controlling the dispensing flow rate is required for small sized tarpaulin fumigations since high-speed discharge from fast dispensing can damage the tarp and undo any sealing that was done. A regulated dispenser is one option to achieve control of dispensing flow rates. The approved dispensing equipment includes a pressure regulator to reduce the cylinder pressure to less than 100 psig exit the pressure regulator. From this pressure ECO₂FUME[®] flows through a flow control further reducing the exit pressure to near ambient. The use of flow restricting nozzles is another option to control the rate of ECO₂FUME[®] dispensing to prevent damage to tape and seals.
4. Determine where the fumigant will be dispensed into the space, and plan for and install required components. Dispensing points should not be located in or attached to commodity packages or within containers.
5. Determine where the fumigant concentrations will be measured and plan for and install required gas sampling lines. Sampling points should not be located near dispensing points to avoid incorrect readings.
6. Cover the material with plastic sheeting using tape, glue or clamps to join individual sheets. If the flooring on which the material is placed is wood or other porous material, it should be covered first with plastic sheeting. Seal the plastic covering to the floor using tape, glue, sand or water “snakes”, shoveling sand or soil onto the ends of the plastic, or by other suitable means. Reinforce by tape or other means, any sharp corners or edges to reduce the risk of tearing the plastic. Plastic sheeting should be a minimum of 2-mil thickness for indoor applications however, 4 or 6 mil is preferred and is more suitable for outdoor use. Ensure that tarp penetrations for dispensing and monitoring are well sealed.
7. Placard the tarped material.

8. Verify that all required safety equipment is available and in good working order.
9. Connect the ECO₂FUME[®] cylinders to the dispensing equipment.
10. Dispense the initial dose of fumigant.
11. Periodically monitor the phosphine concentrations within the space, using suitable gas detection equipment, to ensure that the minimum concentrations are being maintained for the required time.
12. Phosphine gas is highly mobile and given enough time may penetrate seemingly gas-tight materials such as concrete and cinder block. Therefore, adjacent, enclosed areas likely to be occupied must be monitored to ensure that significant leakage has not occurred and phosphine concentrations are at a safe level of 0.3 ppm or below.
13. Dispense additional fumigant as required to maintain the desired phosphine concentrations.
14. When no further fumigant is required, close all cylinder valves. Depressurize the dispensing equipment and disconnect all ECO₂FUME[®] cylinders. Ensure that the valve discharge cap is securely installed and replace the cylinder cap.
15. Before leaving the fumigation site, recheck barricades and placards at all entries into the fumigation space and/or fumigated area to prevent entry by unauthorized personnel during fumigation.
16. When the fumigation is complete, remove the tarp and aerate as appropriate using precautions to prevent exposure to workers (see VIII. AERATION OF FUMIGATED COMMODITIES and IX. E. AERATION AND REENTRY).

Additional Considerations:

1. Do not walk on tarped material once it has been sealed and fumigant has been dispensed.
2. Placard each access to the area where treatment is occurring.
3. Seal off doors, windows and other connections to adjacent areas that may be occupied and placard on the occupied side.

6. APPLICATION TO TRANSPORT CONTAINERS AND TRAILERS

a. General

Railcars and containers, trucks, vans and other transport vehicles shipped piggyback by rail may be fumigated in-transit, however, aeration en-route is prohibited. It is not legal to move trucks, trailers, containers, vans, etc. over public roads or highways until they have been aerated and the warning placards removed. Notify the consignee if the commodity is to be shipped under fumigation. If the consignee is unfamiliar with proper handling of fumigated rail cars and containers fumigated in-transit, it is recommended that they be provided with the necessary information. See Sections VI and VIII of this manual for recommendations on placarding, commodity aeration, and training of persons authorized to remove placarding.

Containers, trucks, and other transport vehicles loaded with bulk commodities, to which ECO₂FUME[®] may be added are treated in essentially the same way as any other storage facility.

ECO₂FUME[®] gas dispensing lines shall not be placed in or attached to commodity packages containing processed food.

b. Procedure for Stationary Container and Trailer Fumigation

1. Develop and follow an appropriate Fumigation Management Plan (Refer to Section IV. G).
2. Determine the empty volume of the trailer or container.
3. Determine the target phosphine concentration and exposure time desired. This should be based on the target pests, commodity temperature, and commodity stored in the container.
4. Calculate how much fumigant will be required, and the dispensing time needed. A regulated dispenser or flow restricting nozzles are the recommended means of dispensing the fumigant.
5. Inspect all sidewalls, roof, floor, and doors for cracks, holes or defects. Seal all openings with tape or caulk. Particular attention should be paid to any drain holes in the floor.
6. Install the ECO₂FUME[®] gas dispensing line and secure it to the door, wall or floor with tape.
7. Close the door and seal with tape, caulk or polyethylene sheeting to prevent gas loss.
8. Affix fumigation placards to all sides and at all openings of the container or trailer.
9. Verify that all required safety equipment is available and in good working condition before fumigation begins.
10. Notify all personnel that fumigant release is about to commence. When trailers attached to tractors and trucks are fumigated, drivers should not be allowed to enter the vehicle until fumigation has ended and the truck is aerated.
11. Dispense the predetermined quantity of ECO₂FUME[®] into the container or trailer.
12. Before leaving the fumigation site, recheck barricades and placards at all doors into the fumigation space and/or fumigated area to prevent entry by unauthorized personnel while fumigation is in progress
13. When the fumigation is complete, aerate as appropriate using precautions to prevent exposure to workers (See Section VIII. Aeration of Fumigated Commodities and Section IX.E. Aeration and Reentry. Adequate monitoring and aeration must be performed to reduce any residual Phosphine levels to below 0.3 ppm.

c. Procedure for In-Transit Container and Trailer Fumigation

Develop and follow an appropriate Fumigation Management Plan (Refer to Section IV. G).

A certified applicator or trained person under his direct supervision must be responsible for adding fumigant and sealing and placarding the container or trailer for transport. The shipper and/or the fumigator must provide written notification to the receiver of the railcar, railroad boxcars, shipping containers and other vehicles which have been fumigated in-transit. A certified applicator or trained person under his direct supervision is responsible for ensuring that a copy of the label and Application Manual precedes or accompanies all transportation containers or vehicles, which are fumigated in-transit. If the Applicator's manual is sent with the transport vehicle it must be placed securely on the outside of the vehicle.

Proper handling at their destination is the responsibility of the consignee. Upon receipt of the railcar, railroad boxcars, shipping containers and other vehicles fumigated in-transit, a certified applicator and/or persons with documented authorized training must supervise the aeration process and removal of the placards.

TRAINING REQUIREMENTS FOR RECEIPT OF VEHICLES OR SHIPPING CONTAINERS FUMIGATED IN-TRANSIT

The trained person(s) must be trained by a Certified Applicator following the EPA accepted product application manual or by other training which is accepted by local or state authorities. The worker training should take place before the in-transit (fumigated) containers arrive and the training should include related instructional materials in addition to the Application Manual. When training has been completed and the employee demonstrates safety knowledge proficiency, the training date must be logged and maintained in the employee's safety training record for a minimum of three years. Refresher training must be done on an annual basis.

This training must cover the following items, each of which may be found in this manual. Additional training in the use of fumigant pesticides may be required by the local or state authorities.

1. How to aerate the vehicle or shipping container and verify that it contains no more than 0.3 ppm phosphine

OR
2. How to transfer the commodity under fumigation to another storage area without prior aeration and ensure that safety limits for workers and people in neighboring areas are not being exceeded during transfer and to placard the new storage area until aeration.
3. How to determine when respiratory protection must be worn.
4. How to protect workers and nearby persons from exposure to levels above the 8-hour time weighted average (TWA) of 0.3 ppm or the 15 minute TWA short- term exposure limit (STEL) of 1.0 ppm phosphine.
5. Proper removal of placards from the vehicle or shipping container

7. APPLICATION TO SHIPS (not for use on barges)

a. General

1. Develop and follow an appropriate Fumigation Management Plan (Refer to Section IV. G.).
2. Important: shipboard, in transit ship or ship hold fumigation is also governed by U.S. Coast Guard Regulation 46 CFR 147A. *Interim regulations for shipboard fumigation*. Refer to this regulation prior to fumigation. For further information contact:
Commandant
U.S. Coast Guard
Hazardous Materials Standards Division
GMSO-3
Washington, DC 20593-0001
3. In addition to the ship fumigation procedures outlined in the following paragraphs (b, c, d, and e), applicators must follow the general procedures for fumigating bulk commodities (see IV. H. 3. c.), spaces (see IV. H. 4. c), or containers (see IV.H. 6. b), as appropriate. Gas circulation assistance may be needed to ensure complete penetration with ECO₂FUME[®] Fumigant Gas for bulk commodity fumigations.

Suggestions are provided under “Additional Considerations” in Section IV.H. 3. c. of “Application to Bulk Commodities.”

b. Pre-Voyage Fumigation Procedures for In-Transit Fumigation

1. Prior to fumigating a vessel for in-transit cargo fumigation, the master of the vessel, or his representative, and the fumigator must determine if the vessel is suitably designed and configured to allow for safe occupancy by the ship’s crew throughout the duration of the fumigation. If it is determined that the design and configuration of the vessel does not allow for safe occupancy by the ship’s crew throughout the duration of the fumigation, then the vessel will not be fumigated unless all crew members are removed from the vessel. The crew members must not be allowed to reoccupy the vessel until it has been properly aerated and a determination has been made by the master of the vessel and the fumigator that the vessel is safe for occupancy.
2. The person responsible for the fumigation must notify the master of the vessel or his representative of the requirements relating to personal protection equipment* and detection equipment, and that a person qualified in the use of all this equipment must accompany the vessel with cargo under fumigation. Emergency procedures, cargo ventilation, periodic monitoring and inspections, and first aid measures must be discussed with and understood by the master of the vessel or his representative.

*Personal protection equipment means a NIOSH/MSHA-approved air purifying full face gas-mask with a chin style mounted canister approved for phosphine, OR a NIOSH/MSHA approved supplied-air respirator with a full face piece for phosphine levels up to 15 ppm. A self-contained breathing apparatus (SCBA) must be worn and operated in a positive pressure mode when phosphine levels are above 15 ppm or at unknown concentrations.

3. Seal all openings to the cargo hold or tank and lock or otherwise secure all openings, manways, etc., that might be used to enter the hold. The overspace pressure relief system of each tank aboard tankers must be sealed by closing the appropriate valves and sealing the openings into the overspace with gas-tight materials.
4. Placard all entrances to the treated spaces with fumigation warning signs.
5. If the fumigation is not completed and the vessel aerated before the manned vessel leaves port, the person in charge of the vessel shall ensure that at least two units of personal protection equipment and one gas or vapor detection device, and a person qualified in their operation be on board the vessel during the voyage. ECO₂FUME[®] cylinders must be disconnected and removed from the vessel before it leaves port.
6. During the fumigation or until a manned vessel leaves port or the cargo is aerated, the person in charge of the fumigation shall ensure that a qualified person using gas or vapor detection equipment tests spaces adjacent to spaces containing fumigated cargo and all regularly occupied spaces for fumigant leakage. If leakage of the fumigant is detected, the person in charge of the fumigation shall take action to correct the leakage or shall inform the master of the vessel, or his representative, of the leakage so that corrective action can be taken.
7. The person in charge of the fumigation shall review with the master, or his representative, the precautions and procedures to be followed during the voyage.

c. Application Procedures for Bulk Dry Cargo Vessels and Tankers

Immediately after application of the fumigant, close and secure all hatch covers, tank tops, butterworth valves, manways, etc.

1. If the fumigation is not completed and the vessel aerated before the manned vessel leaves port, the person in charge of the vessel shall ensure that at least two units of personal protection equipment and one gas or vapor detection device, and a person qualified in their operation be on board the vessel during the voyage.

ECO₂FUME[®] cylinders must be disconnected and removed from the vessel before it leaves port.

2. During the fumigation or until a manned vessel leaves port or the cargo is aerated, the person in charge of the fumigation shall ensure that a qualified person using gas or vapor detection equipment tests spaces adjacent to spaces containing fumigated cargo and all regularly occupied spaces for fumigant leakage. If leakage of the fumigant is detected, the person in charge of the fumigation shall take action to correct the leakage or shall inform the master of the vessel, or his representative, of the leakage so that corrective action can be taken.

d. In-transit Fumigation of Transport Units (Containers) Aboard Ships

In-transit fumigation of transport units on ships is also governed by the U.S. Department of Transportation (DOT). RSPA 49 CFR 176.76 (h) transport vehicles, freight containers, and portable tanks containing hazardous materials and International Maritime Dangerous Goods Code P9025-1 Amdt. 30-00.

1. If the fumigation is not completed and the vessel aerated before the manned vessel leaves port, the person in charge of the vessel shall ensure that at least two units of personal protection equipment and one gas or vapor detection device, and a person qualified in their operation be on board the vessel during the voyage. **ECO₂FUME[®] cylinders must be disconnected and removed from the vessel before it leaves port.**
2. During the fumigation or until a manned vessel leaves port or the cargo is aerated, the person in charge of the fumigation shall ensure that a qualified person using gas or vapor detection equipment tests spaces adjacent to spaces containing fumigated cargo and all regularly occupied spaces for fumigant leakage. If leakage of the fumigant is detected, the person in charge of the fumigation shall take action to correct the leakage or shall inform the master of the vessel, or his representative, of the leakage so that corrective action can be taken.

Application procedures for fumigation of raw commodities or processed foods in transport units (containers) are described in Section IV. H. 6. of this manual.

e. Precautions and Procedures During Voyage

1. Using appropriate gas detection equipment, monitor spaces adjacent to areas containing fumigated cargo and all regularly occupied areas for fumigant leakage. If leakage is detected, the area should be evacuated of all personnel, ventilated, and action taken to correct the leakage before allowing the area to be occupied.

2. Do not enter fumigated areas except in an emergency. If necessary to enter a fumigated area, appropriate personal protection equipment must be used. Never enter fumigated areas alone. At least one other person, wearing personal protection equipment, should be available to assist in case of an emergency.

f. Precautions and Procedures During Discharge

- g. If necessary to enter holds prior to discharge, test spaces directly above cargo surface for fumigant concentration using appropriate gas detection and personal safety equipment. Do not allow entry to fumigated areas without personal safety equipment, unless fumigant concentrations are at safe levels, as indicated by a suitable detector.

8. SPOT FUMIGATION APPLICATION

a. General

ECO₂FUME® Fumigant Gas is recommended for spot fumigation treatment of bins, silos, holding tanks, elevator boots and heads, filters, conveyers, spouting and purifiers, food processing equipment (e.g., sifters, rollers, dusters and other related equipment); and other related equipment found in mills, food and feed processing plants, breweries and similar industries.

Traditionally spot fumigation has been defined as a method of achieving short-term control of insect infestations resulting from the presence of food and food particles that remain within the processing equipment. This practice is meant to control only the adult and larval stages of the insects. It is therefore recommended that spot fumigation be repeated as necessary to control insect re-infestation from the emergence of egg and pupae stages that may not have been completely eliminated by the first treatment.

Spot treatment with ECO₂FUME® Fumigant Gas should be conducted as a supplement to general fumigation. The frequency of treatments is recommended on a monthly basis at a minimum.

b. Develop and Follow an appropriate Fumigation Management Plan (Refer to Section IV.G.)

c. Efficacy

As with all fumigants, the most important aspects of any successful fumigation is the degree to which the space is sealed and the assurance that the minimum fumigant concentrations is maintained for the required time. Given the wide variation in potential infestation scenarios and the difficulty in achieving a well-sealed area in certain situations it is important to note that spot fumigation alone may not completely control the infestation in all cases.

Consideration should be given to an integrated pest management solution which may include the use of fogging chemicals and routine hygiene in conjunction with ECO₂FUME® Fumigant Gas.

Monitoring of the phosphine gas concentrations within and around the fumigated space should be conducted throughout the fumigation. This effort will assist in determining the ability of the fumigation space to hold gas, identifying any leak points that can then be repaired and allow for necessary steps to ensure no one is exposed to unacceptable levels of phosphine. Monitoring of the phosphine concentrations within the fumigation space will also ensure that lethal concentrations are maintained for the minimum exposure time. As a rule of thumb to obtain satisfactory results minimum phosphine concentrations of 50-100 ppm should be observed after 10 hours of the initial addition of ECO₂FUME® Fumigant Gas.

The minimum exposure time for treatment in spot fumigation using ECO₂FUME® Fumigant Gas is 24 hours. Efficacy studies have shown that effective control of adults and larva can be achieved within this time frame with ECO₂FUME® Fumigant Gas. The complete control of the egg and pupae stages is more difficult in spot fumigation applications in 24 hrs due to the difficulty in achieving a gas tight seal in all situations. It is recommended that retrievable insect bioassays be added inside the fumigation space as a measure of assessing the success of each treatment. As spot fumigation is meant as a short-term control measure the frequency of repetitive treatments recommended is one month or less until the problem is brought under control.

d. Recommended Dosage and Exposure Time

The minimum dosage requirement for spot fumigation with ECO₂FUME® Fumigant Gas is 500ppm. Refer to the Application Procedure section of this manual for instructions on calculating of the amount of ECO₂FUME® Fumigant Gas required. Under colder temperature conditions or when certain pieces of equipment including purifiers and sifters can not be readily sealed a maximum dosage of 1000 ppm may be used. The recommended dosage and exposure times are summarized in the following table.

Temperature	Dosage (ppm)	Minimum Duration	Comments
Below 32°F (0°C)	Do not fumigate.	Do not Fumigate	Do not fumigate.
32-59°F (0-15°C)	1000 ppm	24 hours	
60°F & above (16°C & above)	500 – 1000 ppm	24 hours	Choose dosage based upon target insect, level of infestation, ability to achieve gas tight seal.

e. General Procedure for Spot Fumigation

The following procedure is intended to provide general guidelines only for the use of ECO₂FUME® Fumigant Gas in spot fumigation. It is very important that the use of ECO₂FUME® Fumigant Gas for spot fumigation be conducted in compliance with all other instructions found in this manual including sections regarding Health and Safety; Directions for Use; Monitoring; Aeration; Handling, Storage and Transportation of ECO₂FUME® Fumigant Gas cylinders; and the Fumigation Management Plan.

1. Examine the equipment and area to be fumigated thoroughly in order to determine if the equipment can be sealed sufficiently to hold gas.
2. Develop a comprehensive plan before conducting a spot fumigation. This plan should include a thorough understanding of the equipment to be fumigated including all related products and air flow patterns. Review equipment schematics and or diagrams when available.
3. Assess the condition of the equipment for potential sources of leakage and determine the best sealing practice(s). The fumigator should also have a sound understanding of the facility design and the areas surrounding the site of fumigation.
4. Establish and follow all aspects of the Fumigation Management plan to prevent exposure to any workers and bystanders during the fumigation.
5. Establish a security plan to prevent entrance by unauthorized personnel into the placarded fumigation area until after aeration.

6. Phosphine gas can be corrosive to copper, copper alloys and precious metals including gold and silver. Ensure that any sensitive equipment or components of the equipment to be fumigated that may contain these items are removed or protected prior to fumigation.
7. Determine the target phosphine concentration desired for the fumigation. Refer to the Section C Recommended Dosage and Exposure Time guide for spot fumigation in Section (IV.H.8.c). Additional information for calculating the amount of ECO2FUME® Fumigant Gas required is found in Section IV.H.2.d.
8. Calculate the volume within the space to be treated. Since the volume of spot treatment area can vary widely, it is important to make a good estimate of the enclosed volume. If a tarp is involved first calculate the volume taken up by the equipment itself. After tarping is complete, revise the volume estimate based on the additional space contained within the tarp.
9. Calculate how much fumigant will be required, based on the volume calculation, and the means by which it will be dispensed. A regulated dispenser may be required, since high-speed discharge from fast dispensing may damage small tarped areas and undo any sealing that was done. The approved dispensing equipment includes a pressure regulator to reduce the cylinder pressure to less than 100 psig. From this pressure ECO2FUME® Fumigant Gas flows through flow indicators, and the discharge side of the flow indicators is maintained near atmospheric pressure. The use of flow restricting nozzles is another option to control the rate of ECO2FUME® Fumigant Gas dispensing to prevent damage to tarps and seals.
10. Determine where the fumigant will be dispensed into the space, and plan for and install required components.
11. Determine where the fumigant concentrations will be measured and plan for and install required gas sampling lines. Sampling points should not be located near dispensing points to avoid incorrect readings.
12. All equipment to which ECO2FUME® Fumigant Gas will be applied must be sealed. Seal all openings using tape, glue, tarping etc. When tarps are used seal the plastic covering to the floor using tape, glue, sand or water “snakes” or by other suitable means. Reinforce by tape or other means, any sharp corners or edges to reduce the risk of tearing the plastic sheeting. Plastic sheeting should be a minimum of 2-mil thickness for indoor applications however, 4 or 6 mil is preferred and is more suitable for outdoor use. Ensure that any penetrations made in the tarp for dispensing and monitoring purposes are well sealed.
13. Placard the sealed equipment or tarped area as well as all entrances or access points to the area under fumigation with ECO₂FUME® Fumigant Gas warning placards. Phosphine gas is highly mobile and given enough time may penetrate seemingly gas-tight materials such as concrete and cinder block and may escape from sealed or partially sealed equipment. This is generally of no consequence if the tank or bin is out-of-doors. However, leakage into rooms housing treated machinery, equipment, transfer lines, etc. may result in phosphine gas levels above 0.3 ppm. Doors leading to work areas housing treated equipment must be placarded and entry prior to aeration prohibited, unless approved respiratory protection is worn or gas levels less than 0.3 ppm have been measured. Adjacent, enclosed areas likely to be occupied must be examined to ensure that significant leakage has not occurred. Sealing of the fumigated site and/or airflow in the occupied areas must be sufficient to meet exposure standards.
14. Verify that all required safety equipment is available and in good working order.
15. Notify all personnel that fumigant release is about to commence. The area surrounding the equipment being treated should be monitored for phosphine concentrations to ensure that workers are not unduly exposed. It is required that all personnel not trained or involved in execution of the fumigation be restricted from entering the area, until the work is complete. The licensed fumigator must evaluate if workers under a continuous roof, connected buildings or those working near an adjacent outside wall should be vacated to prevent exposure.
16. Connect the ECO2FUME® Fumigant Gas cylinders to the dispensing equipment.
17. Dispense the initial dose of fumigant.

18. Immediately after application close all doors and windows so as to reduce drafts and air currents in the building during the exposure period.
19. Periodically monitor the phosphine concentrations within the space, using suitable gas detection equipment, to ensure that the minimum concentrations are being maintained for the required time.
20. Dispense additional fumigant as required to maintain the desired phosphine concentrations.
21. When no further fumigant is required, close all cylinder valves. When using the regulated dispenser depressurize the equipment and disconnect all ECO₂FUME® Fumigant Gas cylinders. Ensure that the valve discharge cap is securely installed and replace the cylinder cap.
22. When the fumigation is complete, remove any tarps or sealed openings and aerate as appropriate using precautions to prevent exposure to workers (see VIII. AERATION OF FUMIGATED COMMODITIES and IX. E. AERATION AND REENTRY). The use of aeration fans, dust collectors or the opening of windows may help in the aeration process.
23. Determine that the gas concentration is 0.3 ppm or below before removal of warning placards or allowing entry of any personnel without the appropriate respiratory protection into the fumigation area.

V. PERSONAL PROTECTIVE EQUIPMENT (PPE)

A. GLOVES

It is recommended that leather work gloves or leather faced cotton gloves be used when connecting to or disconnecting ECO₂FUME® cylinders from the dispensing equipment.

B. SAFETY GLASSES

When working with pressurized equipment, safety glasses should be worn. Eye protection must be worn to prevent freezing or cryogenic “burns” to the eyes by rapidly evaporating liquid.

C. SAFETY SHOES

It is recommended that steel-toed safety shoes be worn by anyone handling compressed gas cylinders.

D. HAND TRUCKS

Hand trucks are the recommended means of moving individual ECO₂FUME® cylinders about the fumigation site. The hand truck should be designed specifically for compressed gas cylinders and equipped with a suitable chain or strap to ensure the cylinder remains in place. Never move an ECO₂FUME® cylinder without valve cap and cylinder cap in place.

E. RESPIRATORS

1. When respiratory protection must be worn

NIOSH/MSHA approved respiratory protection must be worn during exposure to concentrations in excess of permitted limits or when concentrations are unknown. Respiratory protection (SCBA) must be worn during trouble shooting for leaks if the concentration of phosphine is unknown or known to exceed the STELs for phosphine (1 ppm for 15 minutes) and/or carbon dioxide (30,000 ppm for 15 minutes).

2. Permissible gas concentration ranges for respiratory protection devices

A NIOSH/MSHA approved, full-face gas mask phosphine canister combination may be used at levels up to 15 ppm. Full-face canister respirators shall not be used in phosphine concentrations above 15 ppm phosphine because of the presence of carbon dioxide. Although respiratory protection is not required for CO₂ exposure up to 5,000 ppm, a canister respirator will not provide protection from CO₂ at any concentration.

3. Requirements for availability of respiratory protection

Respiratory protection must be available at the site of application in case it is needed when applying ECO₂FUME®. An adequate number of self-contained breathing apparatus (SCBA) with full facepiece and operated in pressure-demand mode must be available at the site of application. Other types of respiratory protective equipment may be used as appropriate. See the following Table.

NIOSH –RECOMMENDED RESPIRATORY PROTECTION FOR WORKERS EXPOSED TO PHOSPHINE GAS:

CONDITION	MINIMUM RESPIRATORY PROTECTION
(Phosphine gas, ppm)	
0.3- 3	Supplied-air respirator
7.5 or less	Supplied-air respirator operated in a continuous-flow mode
15 or less	Self-contained breathing apparatus with full facepiece or supplied-air respirator with a full facepiece, or air-purifying full-facepiece respirator (gas mask) with a chin-style front- or back-mounted canister.
50 or less	Supplied-air respirator equipped with a full facepiece and operated in pressure-demand mode or SCBA with a full-facepiece and operated in a pressure-demand mode.

F. NOTIFICATION REQUIREMENTS

1. Authorities and on-site workers:

On an annual basis, prior to a fumigation, or more frequently if required by the Fumigation Management Plan, provide and review with local emergency planning committee officials (as defined by Emergency Planning and Community Right-to-Know Act (EPCRA) section 301(c), the MSDS, Applicator's Manual, and other relevant safety information, if available, for use in the event of an emergency.

2. Incidents involving these products:

Registrants must be informed of any incident involving the use of this product. Please call Dan Liebowitz at Cytec Industries Inc. (1-973-357-3460) so the registrant can report all incidents as per requirements of OSHA CFR 29.

3. Theft of products:

Report all thefts of product immediately to proper local officials.

VI. PLACARDING OF FUMIGATED AREAS

The applicator must placard or post all entrances to the fumigated area with signs in English and Spanish bearing:

1. The signal word "DANGER/PELIGRO" and the SKULL and CROSSBONES symbol in red.
2. The statement, "Area and/or commodity under fumigation, DO NOT ENTER/NO ENTRE".
3. The statement "This sign may only be removed after the commodity is completely aerated (contains 0.3 ppm or less phosphine gas and 5,000 ppm or less carbon dioxide). If incompletely aerated commodity is transferred to a new site, the new site must also be placarded and workers and nearby personnel must not be exposed to more than 0.3 ppm phosphine or 5,000 ppm carbon dioxide."
4. The date and time fumigation began and expected completion date.
5. Trade Name and EPA Registration Number of fumigant used.
6. Name, address, and telephone number of the applicator.
7. All entrances to a fumigated area must be placarded. Placards should be placed in advance of the fumigation in order to keep unauthorized persons away. Do not remove a placard until the treated commodity is aerated down to 0.3 ppm or less of phosphine and 5,000 ppm or less of carbon dioxide. To determine whether aeration is complete, each fumigated site or vehicle must be monitored and shown to contain 0.3 ppm or less phosphine gas and 5,000 ppm or less of carbon dioxide in the air space around and, when feasible, in the mass of the commodity. For railcar hopper cars, placarding must be placed securely on both sides of the car near the ladders and next to or on the top hatch into which the fumigant is added.
8. A Certified Applicator or person under his direct supervision must put placards in place after determining how many are required at the container or fumigation site and where they must be placed. An exception is when a trained worker receives raw agricultural commodities under in-transit fumigation and the commodity is transferred to another container before the contents are aerated. In this case, placarding is the responsibility of the trained worker.
9. Persons with documented training in the handling of phosphine products must be responsible for receiving, aerating and removal of placards from vehicles, which have been fumigated in transit. Refer to Section IV. H. 6. c for training requirements. It is recommended that the person responsible for removing the placards be familiar with the physical, chemical and toxicological properties of phosphine and carbon dioxide. They should also be knowledgeable in how to take gas readings, exposure limits, symptoms and first aid treatment for phosphine and carbon dioxide poisoning.

VII. GAS DETECTION EQUIPMENT

There are a number of devices on the market for the measurement of phosphine gas as well as carbon dioxide levels for industrial hygiene purposes. Glass detection tubes used in conjunction with the appropriate hand-operated air sampling pumps are a widely used method. These devices are portable, simple to use, do not require extensive training and are relatively rapid, inexpensive and accurate. Electronic devices are also available for both low level and high phosphine and carbon dioxide gas readings. The newer low-level electronic units as well as the low-level detector tubes can detect 0.01 ppm of phosphine and are suitable for industrial hygiene monitoring. Such devices should be used in full compliance with manufacturers' recommendations.

VIII. AERATION OF FUMIGATED COMMODITIES

A. FOODS AND FEEDS

Tolerances for phosphine residues have been established at 0.1 ppm for animal feeds, grains, nuts and dates; 0.01 ppm for processed foods; and 0.01 ppm in fresh fruits and vegetables. To guarantee compliance with these tolerances, it is necessary to aerate these commodities for a minimum of 48 hours prior to offering them to the end consumer. A shorter aeration period may be permitted if the airborne phosphine was found to be less than 0.3 ppm. Commodities may be analyzed before release to consumers to ensure that phosphine levels do not exceed tolerances.

B. NON-FOOD COMMODITIES

Aerate all non-food commodities to less than 0.3 ppm of phosphine. Continue to monitor densely packed commodities carefully.

C. TOBACCO

Tobacco must be aerated to less than 0.3 ppm. When plastic liners are used, longer aeration periods will probably be required to aerate the commodity down to less than 0.3 ppm. A minimum aeration period of 48 hours is required.

IX. APPLICATOR AND WORKER EXPOSURE

A. PHOSPHINE EXPOSURE LIMITS

Exposure to phosphine must not exceed the 8-hour TWA of 0.3 ppm for applicators and workers during application. All persons in the treated site and in adjacent indoor areas are covered by this exposure standard. Such exposures might occur because of leakage into enclosed areas from fumigation sites or during transfer of unaerated commodity. The short-term exposure limit (STEL) is 1.0 ppm phosphine for 15 minutes.

B. CARBON DIOXIDE EXPOSURE LIMITS

Exposure to carbon dioxide must not exceed the 8-hour TWA of 5,000 ppm or the STEL of 30,000 ppm for applicators and workers during application. Exposure to carbon dioxide must not exceed the TLV of 5,000 ppm for any persons not associated with the application during the fumigation. All persons in the treated site and in adjacent indoor areas are covered by this exposure standard. After application is completed worker or applicator exposure must not exceed 5,000 ppm maximum concentration. Such exposures might occur because of leakage into enclosed areas from fumigation sites during transfer of unaerated commodity. An SCBA is required for any carbon dioxide concentrations exceeding the TLV or TWA.

C. APPLICATION OF FUMIGANT

Because it is not dependent on environmental conditions such as temperature and humidity, ECO₂FUME[®]'s release is instantaneous. This instantaneous release can expose the fumigator to immediate high levels of fumigant. If the fumigator's exposure exceeds the 8- hour TWA of 0.3 ppm of phosphine or the TLV of 5,000 ppm (0.5% by volume) of carbon dioxide, approved respiratory protection such as an SCBA must be worn. Gas concentration measurements for safety purposes must be made using suitable low-level detection equipment. See the "Industrial Hygiene Monitoring" section below. The STEL for phosphine is 1.0 ppm for 15 minutes. The STEL for carbon dioxide is 30,000 ppm.

D. LEAKAGE FROM FUMIGATED SITES

Phosphine and carbon dioxide are highly mobile and given enough time may penetrate seemingly gas tight materials such as concrete and cinder block. Therefore, adjacent, enclosed areas likely to be occupied must be monitored to ensure that significant leakage has not occurred. Proper sealing of the fumigated area and/or the occupied areas should be used to reduce exposure.

E. AERATION AND REENTRY

If the area is to be entered after fumigation, it must be aerated until the level of phosphine gas is 0.3 ppm or below and the level of carbon dioxide is 5,000 ppm (or 0.5% by volume) or below. The area or site must be monitored to ensure that liberation of gas from the treated commodity does not result in the development of unacceptable levels of phosphine and carbon dioxide. Do not allow reentry into treated areas by any person before this time unless protected by an approved respirator.

F. HANDLING UNAERATED COMMODITIES

Transfer of a treated commodity prior to complete aeration is permissible. In the process, people must not be exposed to phosphine and/or carbon dioxide in excess of the permitted exposure limits.

Transfer of incompletely aerated commodity via bulk handling equipment such as augers, drag conveyors and conveyor belts to a new site is permissible; however, the new storage must be placarded if it contains more than 0.3 ppm phosphine or 5,000 ppm of carbon dioxide. Workers who handle incompletely aerated listed commodity must be informed and appropriate measures must be taken (i.e., ventilation or respiratory protection) to prevent exposures from exceeding the exposure limits for phosphine and carbon dioxide. This section does not pertain to transferring fumigated containers or vehicles over public roads. The transfer of fumigated containers or truck trailers over public roads is prohibited.

G. INDUSTRIAL HYGIENE MONITORING

At each site and operation, monitor airborne phosphine and carbon dioxide concentrations in all indoor areas to which fumigators and other workers have had access during fumigation and aeration. Perform such monitoring in workers' breathing zones. This monitoring is performed to determine when and where respiratory protection is required. After gas concentrations have been adequately characterized for various locations, spot-check those areas to determine whether conditions have significantly changed or if an unexpected garlic-like odor is present. Record all monitoring data in an operation log or manual.

H. ENGINEERING CONTROLS AND WORK PRACTICES

If initial monitoring shows that workers are exposed to concentrations in excess of the permitted exposure limits, then engineering controls (such as forced air ventilation) and/or appropriate work practices should be used (such as using personal exposure monitors) where possible to reduce exposure to below permitted limits. In any case, PPE must be worn if phosphine and/or carbon dioxide exposure limits are exceeded.

X. SAFE HANDLING OF COMPRESSED GASES IN CONTAINERS

The following are excerpts from the Compressed Gas Association (CGA) Pamphlet P-1 "Safe Handling of Compressed Gases in Containers". These are provided to assist the user with the more important aspects of cylinder handling. It is recommended that the user be familiar with all aspects of this pamphlet.

1. The user is responsible for the safe use of the container and its contents and for returning the container to the gas manufacturer or distributor in the same safe condition as it was received.
2. The user shall not modify, tamper with, paint, deface, obstruct, remove or repair any part of the cylinder, including the pressure relief device, and the container valve or the valve protection device. Maintenance of the container and

- its valve or relief device (if required) shall be performed only by trained personnel under the direction of the container owner or an authorized representative.
3. The prescribed stamped markings on the container shall be made and kept in a legible condition. The user shall not add, remove or alter any of these markings.
 4. The labels applied by the gas manufacturer to identify the container contents shall not be defaced or removed by the user.
 5. Compressed gas containers shall not be exposed to temperature extremes. High temperatures may result in excessive cylinder pressure. Never apply a flame or heat directly to any part of a compressed gas container or allow it to come in contact with an electrically energized system. High temperatures may also damage the physical integrity of the container. If ice or snow accumulates on a container, thaw at room temperature, or with water at a temperature not exceeding 125°F (51.7°C).
 6. Leaking or defective containers shall not be offered for shipment. Consult the gas supplier for advice under these circumstances.
 7. Any damage that might impair the safety of the container shall be called to the attention of the gas supplier before returning the container.
 8. Where valve outlet caps and /or plugs are provided by the gas supplier, the user shall keep the device on the valve outlet at all times, except when containers are secured and connected to dispensing equipment. Gas-tight valve outlet caps and plugs serve the purpose of containing any residual product and in accordance with the provisions of 49 CFR 173.40 and CSA B340, are mandatory for poison gas containers. The gas-tight valve outlet cap or plug must be checked and tightened securely before return shipment to the gas supplier.
 9. The cylinder valve shall be kept closed at all times (charged or empty) except when the cylinder is in use. Do not use tools such as wrenches and hammers in attempting to open or close valves. An exception is when torque wrenches designed for use with container valve hand wheels are acceptable. Contact the gas supplier if the valve is difficult to operate.
 10. Users of compressed gas containers shall ensure that they are not rolled in the horizontal position or dragged. A suitable hand truck, forklift truck, cylinder pallet system or similar material-handling device should be used with the container properly secured to the device. Never lift containers by using the container cap or magnets.
 11. Caution should be used when handling cylinders to guard against dropping or permitting them to violently strike against each other and other surfaces.
 12. The transfer of compressed gases from one cylinder to another should only be performed by the gas supplier or by personnel who are trained and qualified with the proper transfill equipment and written operating procedures, and who are familiar with the precautions necessary to avoid the hazards of the product being transfilled and with the procedures necessary to comply with all government standards and regulations. Detailed written operating instructions including equipment inspection and maintenance procedures should be provided by the supplier or the transfill equipment and rigorously followed.
 13. Cylinder valve connections that do not fit shall not be forced.
 14. Gas tight connections including piping, regulators and other apparatus shall be kept gas tight to prevent leakage. This can be confirmed by the use of a compatible leak test solution or an appropriate leak detection instrument. DO NOT tighten connections or leaking fittings or attempt other repairs while the system is under pressure.
 15. Prior to disconnecting a cylinder from dispensing equipment, the cylinder valve shall be closed and the dispensing equipment relieved of pressure.
 16. The transportation of compressed gas cylinders in unsuitable vehicles or in closed-bodied vehicles can present serious safety hazards and should be discouraged. Refer to CGA PS-7, CGA Position Statement on the Safe

Transportation of Cylinders in Vehicles, for additional guidance. Shipping compartments should be adequately ventilated.

17. An emergency response plan shall be in place wherever compressed gas containers and products are used, handled, stored or disposed of, according to 29 CFR 1910.120. Only trained personnel shall respond to an emergency situation involving a compressed gas container or product. Personnel shall be promptly evacuated from the immediate area in danger and kept up wind at sufficient distance to avoid any inhalation or contact with potentially hazardous products until safe reentry can be ensured.
18. Before using a gas, read the label and material safety data sheet for information about the material. Exposure to toxic gases shall be kept as low as possible but in no case should concentrations exceed the exposure levels established by the Occupational Safety and Health Administration.

XI. STORAGE OF CYLINDERS

A. GENERAL

The first consideration when planning a storage area for ECO₂FUME[®] cylinders is the needs of the local authorities. It is important that emergency response professionals are aware of all hazardous materials stored in their jurisdiction. They should be provided with an MSDS and detailed information on the quantities of product stored and the nature and location of the storage area.

B. EMERGENCY RESPONSE PLAN

A clearly defined emergency response plan should be developed for the site. This plan should define procedures and outline responsibilities in addressing emergency situations involving ECO₂FUME[®]. All site personnel should be trained in the plan and it should be practiced periodically.

Proper handling procedures as outlined in this manual must be followed. Storing cylinders with the valve discharge cap securely in place will minimize the potential for leaks. Outside storage of cylinders in a secure, well-ventilated, and preferably covered area is recommended. See Part D. of this section for further information.

C. INDOOR STORAGE

The storage of poison gases in occupied spaces is prohibited. However, indoor storage in a separate building with no other occupancy is suitable. The building should be of non-combustible construction (1 hour fire rating), adequately ventilated and equipped with a continuous phosphine monitoring and alarm system that is activated at the TLV of 0.3 ppm. Operating personnel must not enter a building, when the alarm is activated, without wearing a SCBA with full facepiece and operated in pressure-demand mode. In some jurisdictions, the indoor storage of toxic gases is prohibited.

D. OUTDOOR STORAGE

It is recommended that both full and used ECO₂FUME[®] cylinders be stored outdoors in a dedicated and properly designed and labeled storage area.

The following are recommended for outdoor storage:

1. A firm and level surface, preferably reinforced concrete, well drained.

2. Chain link fence topped with three strands of barbed wire, with gate and lock.
3. Covered, if snow accumulation is likely to cause handling problems. Non-combustible construction.
4. Shaded, if high temperatures are expected. Non-combustible construction.
5. Protected from vehicle traffic.
6. A means of securing all cylinders.
7. Away from building ventilation intakes.
8. Equipped with a windsock to indicate wind direction.

E. TEMPERATURE LIMITATIONS

ECO₂FUME[®] cylinders should never be stored where the temperature will exceed 125 °F (51.7 °C). Low temperatures will not affect ECO₂FUME[®]

F. SECURING CYLINDERS

Cylinders must be stored in an upright position and protected from falling. Protection against falls can include the use of cylinder pallets with straps, walls and securing chains, or pens constructed from steel handrail or like construction.

G. LABELING OF STORAGE

The labeling of the ECO₂FUME[®] cylinder storage area should take into account the needs of a variety of organizations. These should include, but not be limited to: corporate policy, insurance carrier, Occupational Safety and Health Administration (OSHA), Right to Know and local emergency response professionals. Storage must be clearly marked with the following signs:

1. Danger, Poison (with skull and crossed bones)
2. Authorized Personnel Only
3. NFPA Hazard Identification Symbols

The National Fire Protection Association (NFPA) developed NFPA Hazard Identification Symbols. This standardized symbol system is designed to provide, at a glance, information regarding the health, fire, and reactivity hazards associated with hazardous materials. The following are the hazard categories and degree of hazard for ECO₂FUME[®].

<u>Category</u>	<u>Degree of Hazard</u>
Health	4 (Severe Hazard)
Flammability	0 (No Hazard)
Reactivity	2 (Moderate)

Materials to properly label the storage area in compliance with NFPA standards can be purchased through most safety supply companies.

NOTE: When using the NFPA Hazard Identification System, the characteristics of all hazardous materials stored in a particular area must be considered. The local fire protection district should be consulted for guidance on the selection and placement of such signs.

XII. TRANSPORT

A. GENERAL

ECO₂FUME[®] is classified as a poison gas by the United States Department of Transportation (DOT) and it shall only be transported in accordance with DOT regulations. All persons involved in the transport of or the preparation of cylinders for transport should be trained in and familiar with the specifications of 49 CFR (Code of Federal Regulations).

B. TRANSPORT DESIGNATIONS

The following transport designations apply to ECO₂FUME[®]:

Proper Shipping Name:	Liquefied gas, toxic, n.o.s. (contains phosphine) (Inhalation Hazard Zone D)
Hazard Class:	2.3
Identification Number:	UN 3162
Shipping Label:	Poison Gas

C. TRANSPORT REQUIREMENTS

1. Package Preparation

ECO₂FUME[®] cylinders shall not be transported unless:

- The cylinder valve is fully closed.
- The gas tight outlet cap is secured on the valve outlet.
- The cylinder cap is secured.
- The cylinder has a readable, proper shipping label.

2. Cylinder Contents

Used ECO₂FUME[®] cylinders can still contain residual gas, and shall be offered for transport and transported as if they are full. Check with your distributor if you have questions about shipping ECO₂FUME[®] cylinders.

3. Documents

Proper documentation is required by law, for the transport of any hazardous material. The documentation accompanying the shipment of ECO₂FUME[®] (whether full, partially full, or empty) must include the labeling, a bill of lading, placard, and the MSDS. The documents must clearly identify the quantity and nature of all hazardous materials being transported or offered for transport by a second party. All persons generating such documents should be trained in their preparation.

4. Vehicle Loading

ECO₂FUME[®] cylinders shall only be loaded into unoccupied spaces of vehicles. All cylinders shall be secured from movement during transport.

5. Vehicle Markings

Vehicles transporting ECO₂FUME[®] shall be placarded in accordance with table I of 172.504 of 49 CFR. Consideration should be made for other hazardous materials that are concurrently being transported. Proper placarding should take into account all hazardous materials on board.

6. Use of Common Carriers

Shipment of ECO₂FUME[®] cylinders by common carrier is permitted, provided the carrier meets certain criteria. Contact an authorized ECO₂FUME[®] distributor for an approved list of common carriers.

7. Driver Qualifications

Anyone operating a vehicle that is carrying hazardous materials must be in possession of a current Commercial Drivers License (CDL) with Hazardous Material Endorsement.

XIII. DISPOSAL

Once used, ECO₂FUME[®] cylinders are to be returned only to an authorized distributor or their designated point of return. This applies to all cylinders, regardless of the quantity of material remaining in the package. Disposal of the cylinder contents (mixture of phosphine and carbon dioxide) is prohibited. If the cylinder is partially full do not release the remaining gases; just send the cylinder to authorized distributor.

XIV. SPILL AND LEAK PROCEDURES

A. GENERAL

All releases can produce high levels of toxic phosphine gas, and therefore, attending personnel must wear a SCBA with full facepiece and operated in a pressure demand mode when the concentration of phosphine gas is unknown. If the concentration is known, other NIOSH/ MSHA approved respiratory protection must be worn.

B. WHAT TO DO

In the event of an accidental release, evacuate the area immediately. Only trained emergency responders should attempt a response into the leak area. If it is possible to shut off the source of the leak from a remote area, it should be done. Otherwise, evacuate the area and call for assistance.

C. WHO TO CALL

CYTEC operates a 24-hour Emergency Response and Incident Management System (ERIM). For emergencies involving spill, leak, fire, exposure or accident call CHEMTREC: 1-800/424-9300. Outside the US or Canada call 703/527-3887.

D. EMERGENCY RESPONDERS

All emergency responses should be made in level B protection, which includes neoprene, butyl rubber or PVC, gloves; Seranex coated Tyvek suit, rubber boots and an air-supplied respirator.